



FITTING INSTRUCTIONS

Part Number: **3434190**
Product **DELUXE BULL BAR**
Description:
Suited to **MITSUBISHI PAJERO '14 Onwards (NX)**
vehicle/s:

WARNING

REGARDING VEHICLES EQUIPPED WITH SRS AIRBAG:

When installed in accordance with these instructions, the front protection bar does not affect operation of the SRS airbag.

ALSO, NOTE THE FOLLOWING:

- ◆ This product must be installed exactly as per these instructions using only the hardware supplied.
- ◆ In the event of damage to any bull bar component, contact your nearest authorised ARB stockist. Repairs or modifications to the impact absorption system must not be attempted.
- ◆ Do not use this product for any vehicle make or model, other than those specified by ARB.
- ◆ Do not remove labels from this bull bar.
- ◆ This product or its fixing must not be modified in any way.
- ◆ The installation of this product may require the use of specialized tools and/or techniques
- ◆ It is recommended that this product is only installed by trained personnel
- ◆ These instructions are correct as at the publication date. ARB Corporation Ltd. cannot be held responsible for the impact of any changes subsequently made by the vehicle manufacturer
- ◆ During installation, it is the duty of the installer to check correct operation/clearances of all components
- ◆ Work safely at all times
- ◆ Unless otherwise instructed, tighten fasteners to specified torque

ARB 4x4 ACCESSORIES

Corporate Head Office

42-44 Garden St
Kilsyth, Victoria
AUSTRALIA 3137

Tel: +61 (3) 9761 6622
Fax: +61 (3) 9761 6807

Australian enquiries
North & South American enquiries
Other international enquiries

sales@arb.com.au
sales@arbusa.com
exports@arb.com.au

www.arb.com.au

GENERAL CARE AND MAINTENANCE

By choosing an ARB Bar, you have bought a product that is one of the most sought after 4WD products in the world. Your bar is a properly engineered, reliable, quality accessory that represents excellent value. To keep your bar in original condition it is important to care and maintain it following these recommendations:

- Prior to exposure to the weather your bar should be treated to a Canuba based polish on all exposed surfaces. It is recommended that this is performed on a six monthly basis or following exposure to salt, mud, sand or other contaminants.
- As part of any Pre Trip Preparation, or on an annual basis, it is recommended that a thorough visual inspection of the bar is carried out, making sure that all bolts and other components are torqued to the correct specification. Also check that all wiring sheaths, connectors, and fittings are free of damage. Replace any components as necessary. This service can be performed by your local authorized ARB Stockist.

FITTING REQUIREMENTS

REQUIRED TOOLS FOR FITMENT OF PRODUCT:

| | |
|---|---|
| BASIC TOOL KIT | ELECTRIC DRILL WITH COMPLETE METRIC DRILL SET |
| JIG SAW WITH BLADE SUITABLE FOR PLASTIC | LOW TACK MASKING TAPE |
| FILE | UTILITY KNIFE |
| TAPE MEASURE | CLAMP |
| STEEL RULER | WHITE FELT MARKER |
| HACK SAW | TORQUE WRENCH |
| TOUCH UP PAINT ANTI CORROSION | RIGHT ANGLE ELECTRIC DRILL |
| POLYURETHANE GLUE | |

HAVE AVAILABLE THESE SAFETY ITEMS WHEN FITTING PRODUCT:

Protective eyewear



Hearing protection



NOTE: 'WARNING' notes in the fitting procedure relate to OHS situations, where to avoid a potentially hazardous situation it is suggested that protective safety gear be worn or a safe work procedure be employed. If these notes and warnings are not heeded, injury may result.

FASTENER TORQUE SETTINGS:

| SIZE | Torque Nm | Torque lbft |
|------|-----------|-------------|
| M6 | 9Nm | 7lbft |
| M8 | 22Nm | 16lbft |
| M10 | 44Nm | 32lbft |
| M12 | 77Nm | 57lbft |

PARTS LISTING

| APPLICATION. | PART NO. | QTY | DESCRIPTION |
|-------------------------------------|----------|---------------------|---------------------------------|
| FIT MOUNTS TO CHASSIS | 3759603R | 1 | MOUNT ASSY RH |
| | 3759603L | 1 | MOUNT ASSY LH |
| | 3757509R | 1 | BRKT CHASSIS OUTBOARD RH |
| | 3757509L | 1 | BRKT CHASSIS OUTBOARD LH |
| | 3757508R | 1 | BRKT CHASSIS INBOARD RH |
| | 3757508L | 1 | BRKT CHASSIS INBOARD LH |
| | 3199915 | 6 | PLATE CAGE NUT |
| | 6151302 | 6 | NUT CAGED M10 1.8-3.2 |
| | 6151357 | 16 | BOLT SEMS M10 x 30mm |
| | 6151321 | 10 | NUT FLANGE M10 |
| FIT BAR TO MOUNTS | 6151357 | 8 | BOLT SEMS M10 x 30mm |
| | 6151321 | 8 | NUT FLANGE M10 |
| FIT LIGHTS AND MOULDINGS | 3162466R | 1 | BUFFER 260x230 RH |
| | 3162466L | 1 | BUFFER 260x230 LH |
| | 3163082 | 1 | KIT SURROUND ARB FOGLIGHT |
| | 6821300 | 1 | LAMP KIT LED IND CLR WITH DRL |
| | 6151128 | 12 | NUT HX FLANGE M6 |
| | 6821116 | 4 | GROMMET NYLON SNAP IN TYPE |
| FIT STONE GUARDS | 6523018 | 1 | STONE GUARD |
| | 6522714R | 1 | WING UNDERPANEL RH |
| | 6522714L | 1 | WING UNDERPANEL LH |
| | 6151300 | 14 | NUT CAGED M6 2.6-3.5 |
| | 4581082 | 14 | WASHER FLAT M6x19 BLK ZN |
| | 4581287 | 14 | WASHER SPRING M6x2.5x1.6 BLK ZN |
| | 6151711 | 14 | SCREW BTN HD TX M6x25 BLK ZN |
| | 6151301 | 2 | NUT CAGED M8 3.3-4.7 |
| | 6151546 | 2 | BOLT HX HD M8x1.25x25 BTZP480 |
| | 4581075 | 2 | WASHER FLAT M8 BLK ZN |
| 4581047 | 2 | SPRING WASHER M8 BZ | |
| FIT WINCH COVER PANEL | 6522944 | 1 | PANEL COVER PRADO 150 |
| | 6191006 | 1 | EXTRUSION WINCH COVER |
| | 6151256 | 2 | SCREW BTN HD M6x16SS |
| | 4584295 | 2 | FLAT WASHER M6x12 BZ |
| | 6151128 | 2 | NUT HX FLANGE M6 |
| FIT CONTROL BOX | 3756499 | 1 | BRKT CONTROL BOX MOUNT MULTIFIT |
| | 6151021 | 2 | BOLT M8x1.25x20 HX HD ZP |
| | 4581044 | 2 | WASHER FLAT M8x17x1.6 |
| | 6151132 | 2 | NUT HX FLANGE M8 |
| | EG50 | 2 | RUBBER GROMMET |
| FIT LICENSE PLATE (WINCH INSTALLED) | 3751451 | 1 | BRKT NUMBER PLATE |
| | 6151128 | 4 | NUT HX FLANGE M6 |
| | 6151017 | 4 | BOLT M6x16mm ZP |
| | 6151046 | 4 | WASHER FLAT M6 ZP |
| FIT LICENSE PLATE (NON-WINCH) | 6821189 | 2 | GROMMET RND FC |
| | 6151384 | 2 | SCREW ST 5.2 X 16 |

| | | | |
|---------------------------|---------|----|---------------------------------|
| FIT SIREN MOUNT | 3758030 | 1 | BRKT SIREN MOUNT |
| | 6151303 | 3 | NUT CAGED M8 1.8-3.2 |
| | 4581075 | 3 | WASHER FLAT M8 BLK ZN |
| | 4581047 | 3 | SPRING WASHER M8 BZ |
| | 6151262 | 3 | BOLT M8x1.25x20 Gd 8.8 BZ |
| FENDER LINER RE-FASTENING | 6151128 | 4 | NUT HX FLANGE M6 |
| | 4581082 | 6 | WASHER FLAT M6x19 BLK ZN |
| | 4581287 | 6 | WASHER SPRING M6x2.5x1.6 BLK ZN |
| | 6151711 | 6 | SCREW BTN HD TX M6x25 BLK ZN |
| MISCELLANEOUS | 6191025 | 2 | PINCH WELD 480mm |
| | 3789363 | 1 | BUMPER CUT TEMPLATE |
| | 180302 | 10 | CABLE TIE 4.8 x 180mm |
| | 4581040 | 2 | WASHER FLAT M10x25x3 ZP (RFL) |
| | 6151074 | 2 | BOLT UNC 3/8 x 1 3/4 Gd 8.8 |

FITTING PROCEDURE



Note: Read the instructions thoroughly before starting.

1. Remove stone tray.

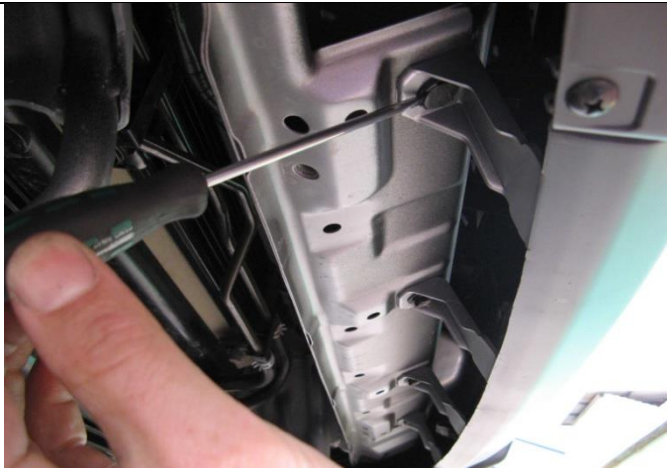

2. Remove plastic scrivets and bolts securing lower bumper tabs.



3. Remove screws securing fender liner to bumper and bumper bracket in wheel arch area.
4. Remove liner and bumper retaining brackets.



5. Undo vertical screws securing bumper to fender



6. Remove scrivenets securing grille across the top and pull grille upward to release lower clips.

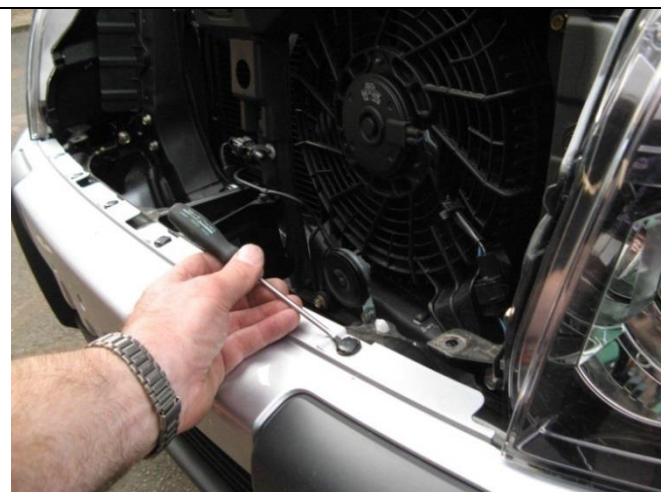

7. Remove upper bumper retaining scrivenets.



8. Remove number plate.
9. Remove scrivenets behind number plate position



10. Free the end of the flare from the bumper by pulling outward in the lower region as shown.



11. With flare loose to bumper, pull the bumper end outward and forward to release it from the holding bracket on both sides then remove bumper entirely.
12. Place bumper on soft non-abrasive surface as the upper part will be reused and should not be damaged.



13. Undo upper cross member fasteners as shown on both end.

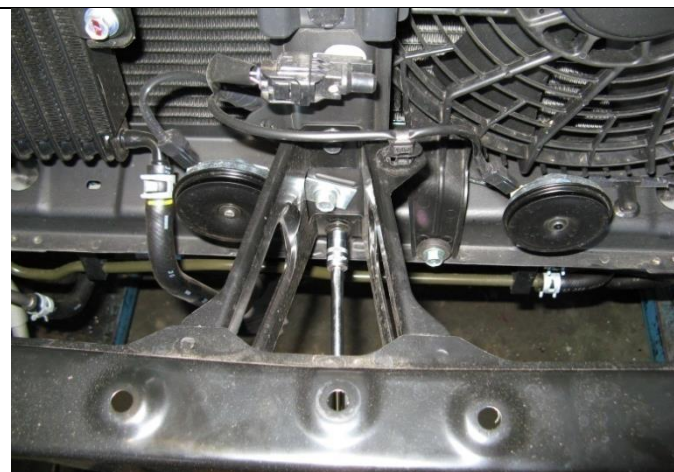

14. Remove cross member central fasteners then set aside.



15. Remove the Fog lights, Wiring harness and washer hoses (if fitted) from the back of the bumper and set aside.

Retain wiring loom, headlight washer hoses and discard of fog lights.



16. If washer assemblies fitted (circled for reference in picture), remove and set aside.



17. Place bumper back on vehicle including securing wing area of bumper into retaining clips.

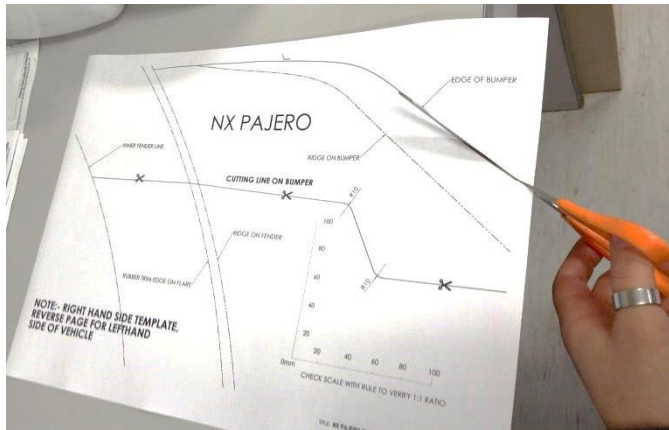

18. Cut bumper trim template supplied.

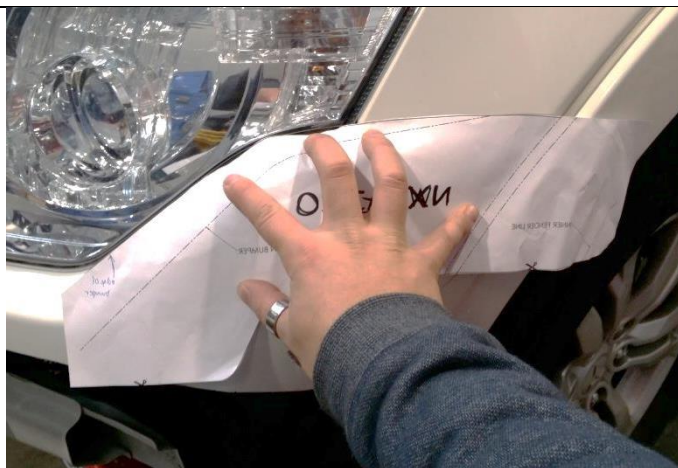

19. Position/align bumper trim template with edges listed on template and mark cut line.



20. Using a spirit level, continue marked cut line onto flare.



21. Continue marked cut line on bumper as shown using bottom edge of rectangular hole as guide.

Stop line 60mm from edge of chrome grille.

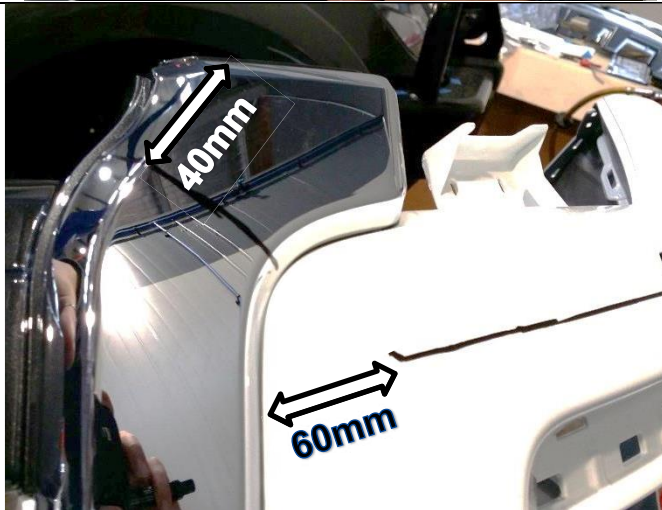

22. Mark a point on the edge of the chrome grille face 40mm from the top edge as shown and draw a line 40mm across and parallel to top edge on chrome piece.

23. Mark a line joining end point of line drawn towards end point of line drawn in step 21.

24. Continue marked line drawn in step 22 all the way around grille piece as shown.

Repeat steps 19 - 24 for other side.

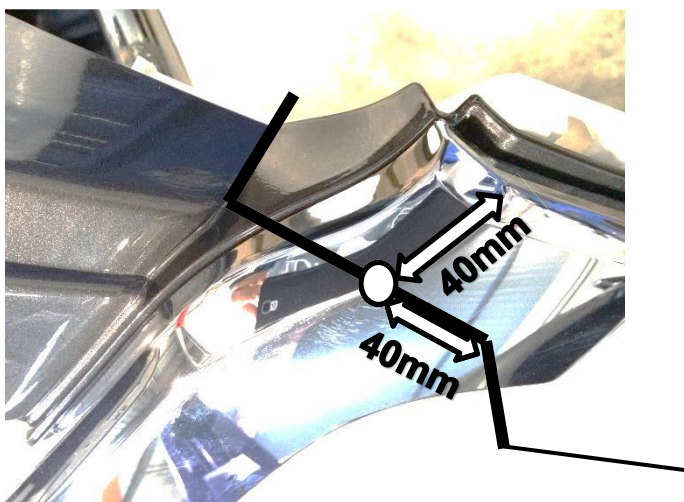



25. Trim bumper and grille along marked edges using a jig saw (apply masking tape to either side of cut lines before cutting).

NOTE: There is a metal bracket in the outboard section of the bumper that will need to be cut through.

NOTE: There are several layers of plastic that will need to be cut through for grille section.



26. Mark cut lines on each end of the cross member. The edge of the cut is 25mm inboard of the M6 hole as shown.



27. Using a jig saw or angle grinder with cutting wheel, cut along the line.



28. Mark and drill a 7mm hole on the LHS of the cross member, in the same position as the existing hole on the RHS.

29. De-burr cut edges and touch up with anti-corrosion paint





30. Refit ends of cross member in original positions.



31. Refit bumper ends

32. Mark a line on the bumper hard up against the lip of the rubber trim on the flare.

NOTE: This is in preparation for a slot which allows the pinch weld, fitted later in the process, to seamlessly fit across the end of the flare onto the bumper.

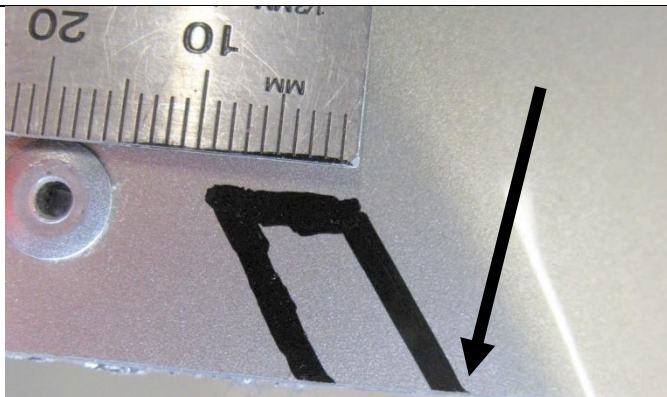

33. Remove the bumper ends.

34. Mark out slot as shown 20mm high x 10 mm wide, starting **next** to the marked point from step 32 (circled).

CRITICAL: Slot should not be seen once flare is refitted with pinch weld in place.

35. Notch out the marked area with a grinder and cutting wheel. Note that there is a metal bracket behind the plastic.

36. Refit the bumper sections, clipping the outboard area into the fender clips and the inboard area into the clips on the cross member ends.

37. Fit the existing screw to vertically secure the bumper end to the fender.

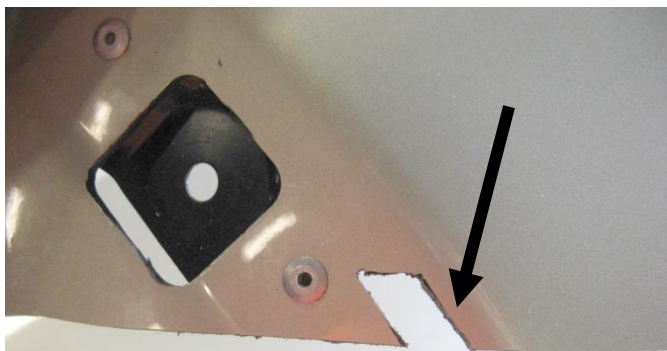



38. To secure inboard end of bumper section, fit a cable tie to the remaining lug on the bumper and through the newly drilled hole in the cross member ends. This cable tie when pulled tighter can adjust the position of the bumper to the bull bar, so wait until after the bar is fitted before trimming the cable tie off.

NOTE: Viewed from underneath



39. Mark and then trim one end of each of the pinch welds to suit the angle of the wheel arch area of the flare. Use a cutting wheel in a grinder as there is a metal spring channel frame inside the pinch weld.



40. Apply pinch weld to both chrome grille piece and bumper (two separate pieces need to be cut).

Repeat for opposite side.

NOTE: Apply small amount of polyurethane glue to edge of chrome piece before applying pinch weld in order to secure it properly.



41. **If siren fitted** to front outboard side of RHS chassis, it will need to be removed to be refitted later.

42. Use a pin punch to punch through the steel pins then drill out the rivets and remove siren.





43. Bend small tab retaining plug located on RHS outer chassis rail upwards using pliers (to give better clearance to chassis bracket).

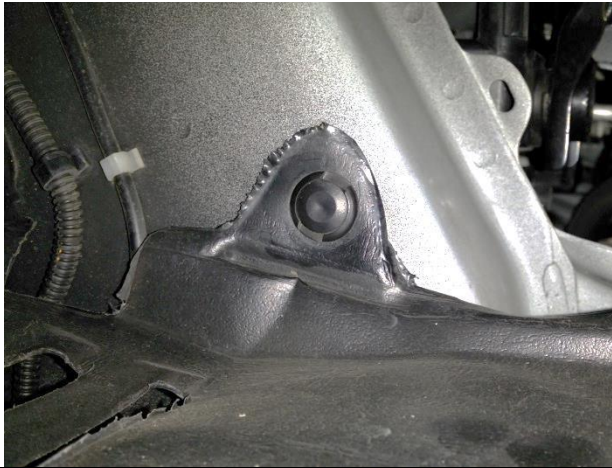

44. Remove scrivet retaining wheel arch guard to outer chassis rail (both sides). This will be trimmed at a later stage.

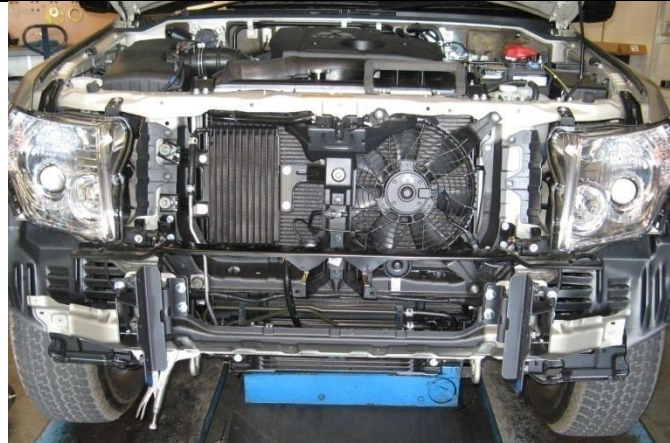

45. Fit mount bracket sets with reinforcing plates to front of vehicle as shown. Use M10 fasteners sets to hold in position.

NOTE: Return flanges on brackets face inboard as shown.



46. Remove metal braces fixing guards to crash beam

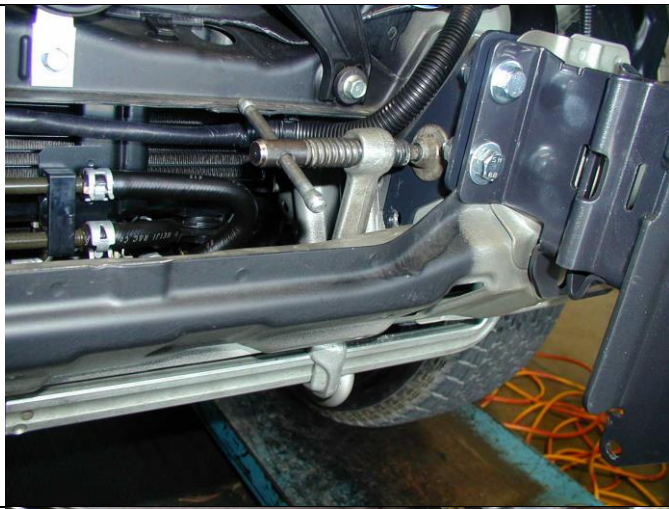

- 47. Use a large 'G' clamp to hold reinforcing brackets hard up against the chassis sides. (LHS shown)
- 48. When in place tighten bolts.

 M10 – 44Nm

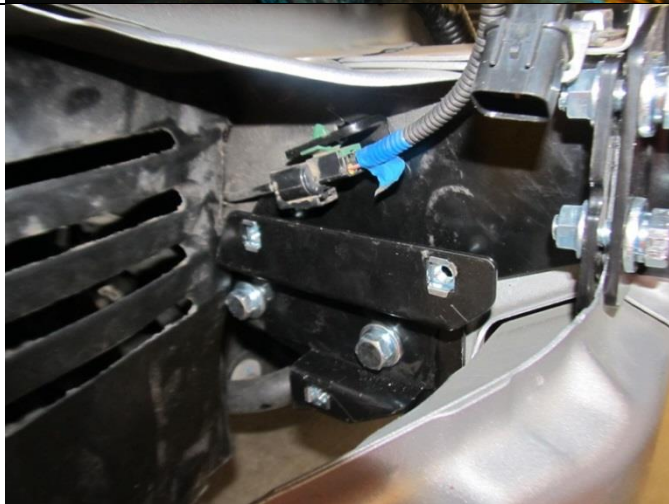

- 49. Outboard reinforcing bracket shown on RHS Showing Siren bracket fitted.



- 50. **If refitting siren** fit cage nuts as shown top view
- 51. Fit bracket to side of brace shown on outer RHS of vehicle using M10 SEMS bolts and cage nuts supplied. **NOTE: You may have to loosen bolts in front flange of reinforcing bracket**
- 52. Fix siren to bracket with M8 bolt and washer sets, reconnect electrical and tighten all bolts to specified torque.

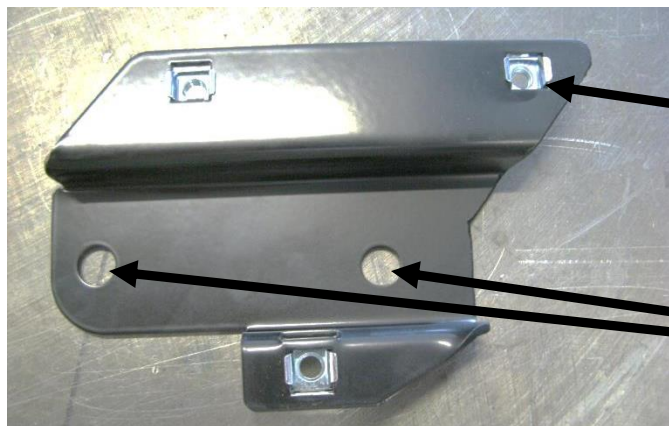

This end to front of vehicle

Use these holes to bolt to vehicle with reinforcing bracket in between

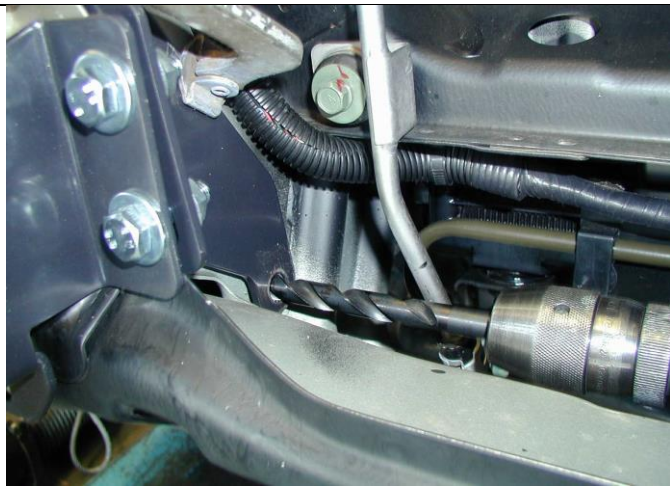

53. Inboard bracket shown on RHS
54. Drill 1 x Dia 10.5 hole on the inboard side and 2 x holes on the outboard side using existing holes in reinforcing brackets to guide drill.

NOTE: If regular drill is too big, may need to use right angle drill.

NOTE: Rearmost hole on outboard side of RHS chassis rail already exists, open up to 10.5mm.

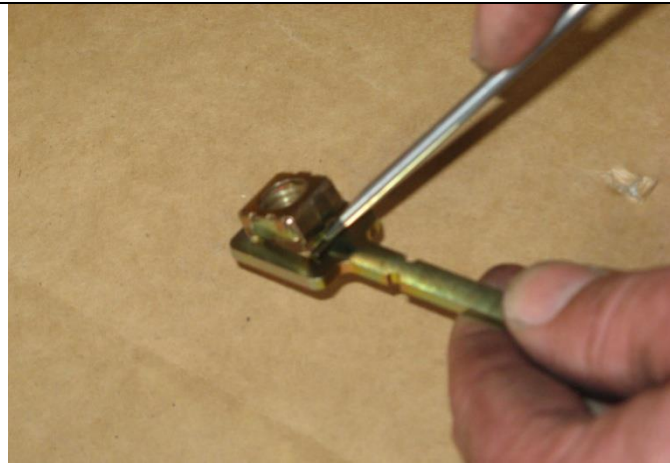
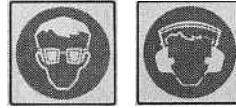

55. Fit 6 x cage nuts to access arms as shown.



56. Estimate the bend profile and then bend each of the access arms so that the cage nuts will align with the 3 x drilled holes in each chassis.
57. Feed the arms through the lower holes in chassis one at a time and secure with M10 SEMS fasteners through holes in brackets.
58. Once all are through and started do up tight.



59. Bend the arms back and hard against the chassis.



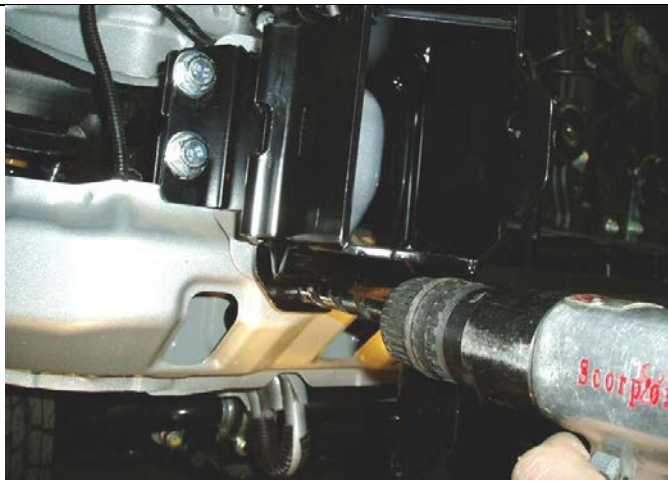

60. Drill Diameter 10mm pinning hole in lower flange of mount bracket into the vehicle Cross member.

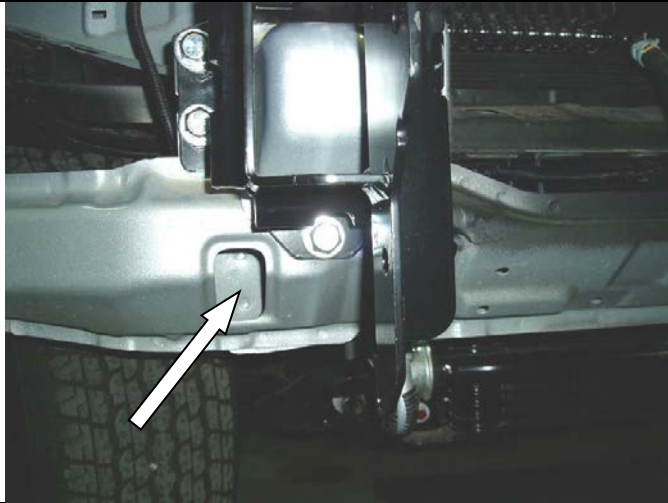
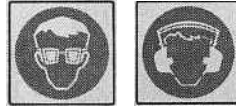

61. Fit M10 SEMS bolt and load flange nut from inside cross member then do up tight to specified torque.

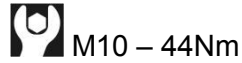

62. Reclip electrical loom connector into new bracket flange both sides of vehicle.

WINCH FITMENT ONLY

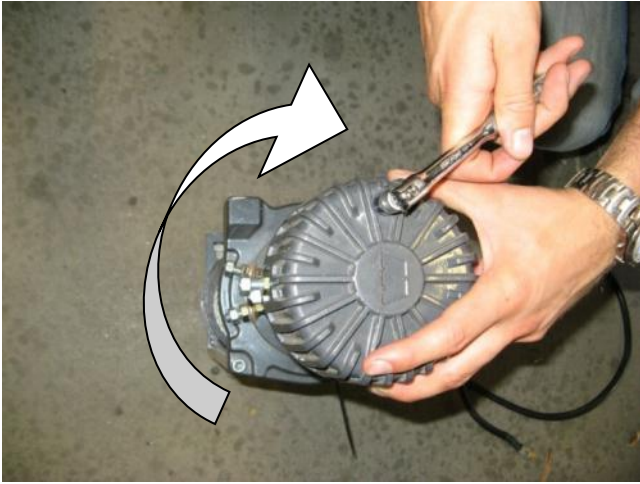

IF FITTING A WINCH

63. Rotate the winch motor 90 degrees as shown

NOTE: Follow the winch manufacturer's instructions regards motor rotation and drainage requirements.

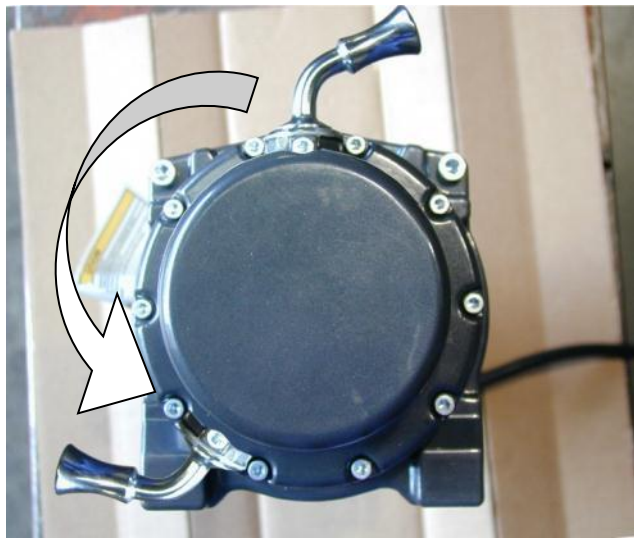

64. Remove the cap head screws retaining the gearbox to the winch drum. Carefully lift the gearbox a small amount (5 mm) and rotate 144 degrees counter clockwise (four hole spacings) and re-fit the cap screws . This places the winch handle in the correct orientation.

65. Lay the winch on a suitable flat surface and place the bull bar on top so that the wire rope will feed through from the bottom.

66. Using the two 3/8" x 1 1/2" long bolts, M10 flat and spring washers, attach the bull bar to the winch through the top two bolt holes



67. Remove the cir clips from the bottom of the vertical rollers of the fairlead and push the pin upwards. Push the vertical rollers inwards on the lower edges as shown and using two 3/8" x 1 3/4" bolts M10 flat and flat washers, attach the lower section of the roller fairlead to the bull bar and winch.

 3/8" UNC - 44 Nm.

68. Replace the cir clips on the vertical rollers on both sides.

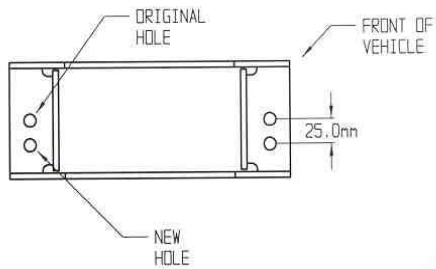

69. If the RFL does not have the second set of holes 25mm lower than the ones marked original in this sketch, mark out and drill a new hole set of the same diameter as original

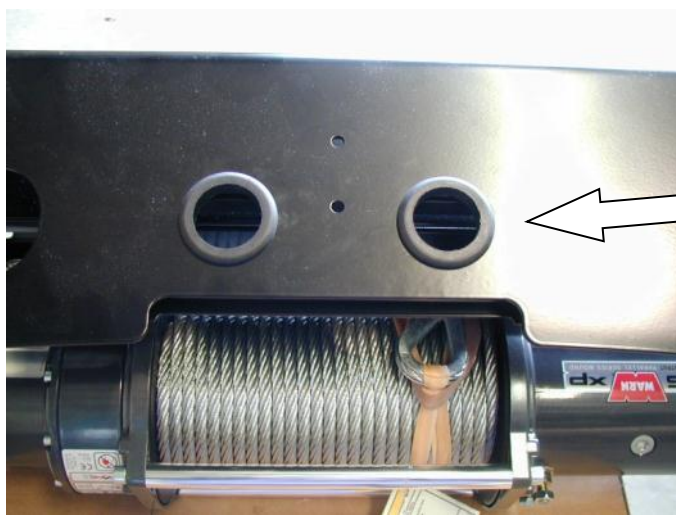

70. Insert the two rubber grommets into the top face of bull bar.



71. Attach the control box to the control box bracket as shown.

72. Fit the control box to the bull bar with two M8 x 20 mm bolts, M8 flat washers and M8 flange nuts.

 M8 - 22 Nm.



73. Run the cables through the rubber grommets and connect to the winch as per the wiring diagram supplied with the winch.

74. Using cable ties fix the cables securely and ensure they are well away from any moving, sharp or hot surfaces.

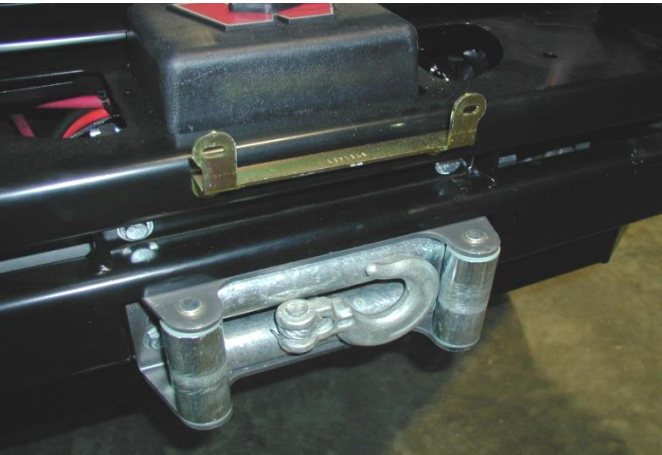

75. Install licence plate bracket to bar using 2x M6 flange nuts, 2x M6x16mm bolts and 2x M6 washers.

NON-WINCH BAR FITMENT



76. Apply rubber mould to edge of winch hole cover panel and trim off excess.

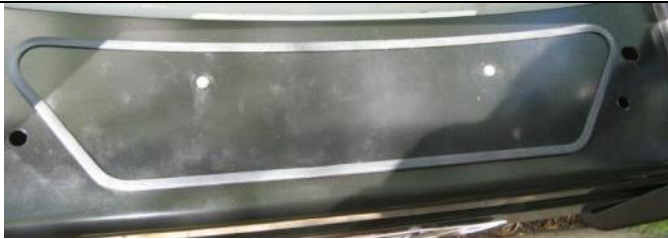

77. Fit panel to top face on bull bar using stainless steel 2 x M6 dome head screws and stainless steel flat washers and flange nuts.

78. **NOTE: The flat washers are to be sandwiched between panel and top face of bull bar to stop the panel pulling down to form depression around screw heads.**

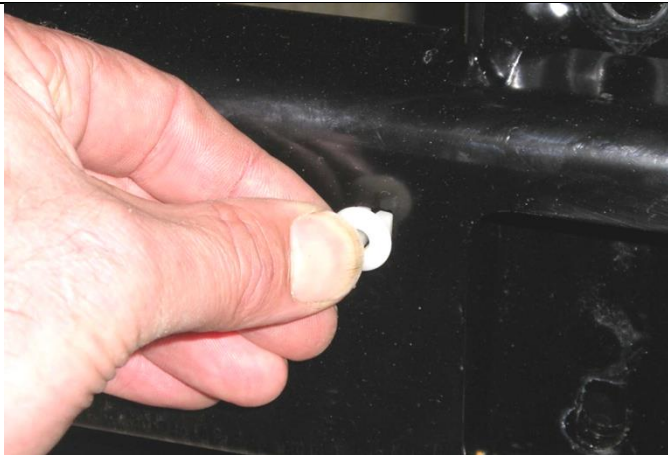

79. Fit 2 x large round head grommets to front face of bull bar in square holes.



80. Fit number plate using black dome head screws inserted into grommets.

BAR PREPARATION GENERAL CONTINUED



81. Insert the side buffers through the holes and fix using 12x M6 flange nuts.



82. Fit Headlight Washers to Bar if required, refer to Washer Kit Fitting Instructions.

NOTE: Refer to Washer Kit 3500570 Instructions.

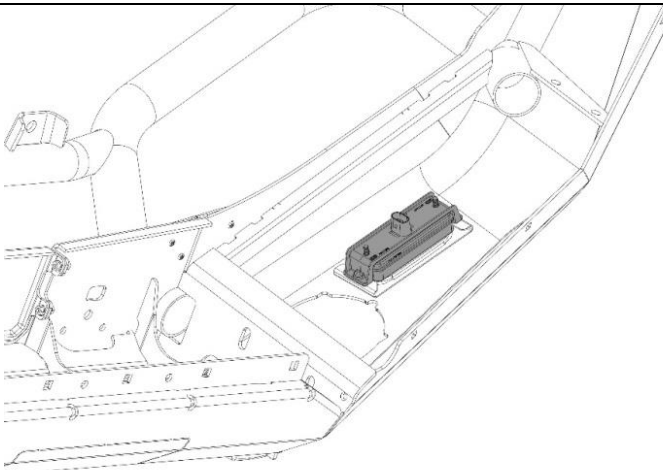

83. Fit the small plastic grommets to the bar and attach the combination LED lamps to the bar using the screws provided with the lamp kit.

84. Wire the combination lamp (kit: 6821300) to the vehicles indicator and clearance lamp wiring.

Caution: Cable tie all cables together and keep all cables clear of sharp edges and moving parts.

Note: Will need to remove headlights to get access to vehicle indicator wiring.

| Function | LED Wire | Vehicle Wire | Vehicle connector |
|-----------------|----------|---------------------------------------|--------------------------|
| Ground | Black | Black | 3 pin (behind headlight) |
| Indicator | Green | Green/Yellow (LHS) Green/Red (RHS) | 3 pin (behind headlight) |
| Clearance | Red 1 | Green | 3 pin |
| Daytime Running | Red 2 | Grey | 3 pin |



85. Assemble and install combination light surrounds (p/n 3163082) as per instructions no. 3789190 supplied with surround kit. Note: Optional fog lamps can be installed at this point as per fitting instruction supplied with fog lamp kit no. 3500640.

CAUTION: Cable-tie all cables together and keep all cables clear of sharp edges and all moving parts.

86. Check the operation of all lights wired during bar fitment



87. Using a black spray pack, paint the exposed colour coded area of the cross beam so it does not show.



88. Offer bar to vehicle and loosely fasten using 6x M10x30mm SEMS bolts and 6x M10 flange nuts.



89. Adjust height of bar until there is an even gap on both sides of approximately 15-22mm between the bumper and bull bar wing.

90. Tighten 6x M10 fasteners securing bull bar to mounts once happy with the position.



M10 – 44Nm



91. Drill 2x pinning holes using $\Phi 10.5\text{mm}$ drill bit through existing holes in mount bracket lower flange area.
92. Insert 2x M10x30mm SEMS bolts and 2x flange nuts and tighten to specified torque.



 M10 – 44Nm



93. Trim sections of wheel arch guard using lower edge of crash beam and wing as guide.



94. Tuck fender liner into inside rear of wing flange.



95. Drill holes in fender liner using $\Phi 7.0\text{mm}$ holes in wing return flanges as a guide and fasten fender line with 4 x M6x25mm black bolts, M6 washers, M6 spring washers and M6 flange nuts.



 M6 – 9Nm



96. Drill hole in fender liner (each side) corresponding to weld nut on the cross member and fasten with 2x M6x25mm black bolts, M6 flat washers and M6 spring washers.
97. Trim the liner with scissors or sharp blade to align with under panel and lower cross member.



 M6 – 9Nm

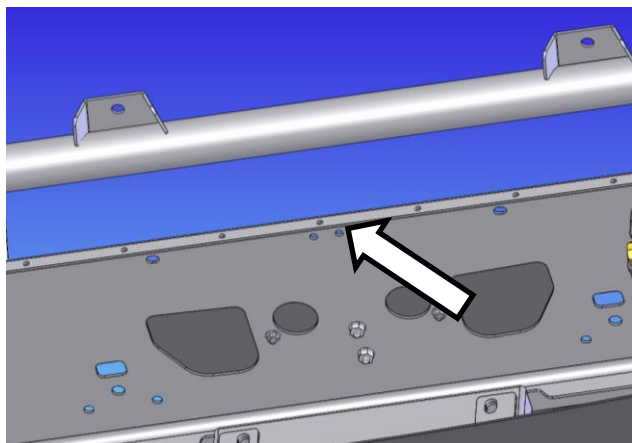

98. Carefully secure all loose wiring and washer bottle hoses to bar using zip ties supplied in fitting kit.



99. Re-fit grille loading vertically, noting that there are pins on the lower section which align with holes in the top face of the bull bar.
100. Re-fit stone tray removed in step 1.
101. Check that indicators are not rubbing on the cut edge of the bumper. If this is the case, locally trim the bumper edge.

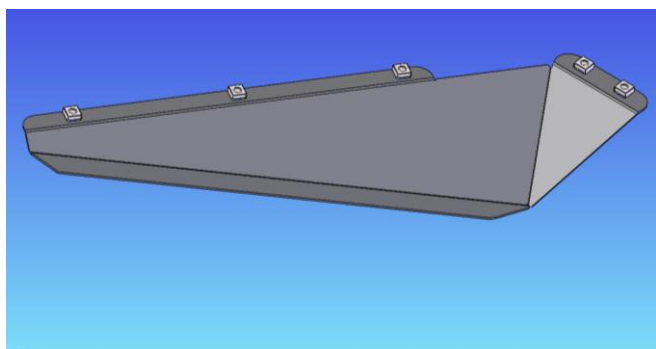

102. Fit 5x M6 cage nuts to each wing underpanel

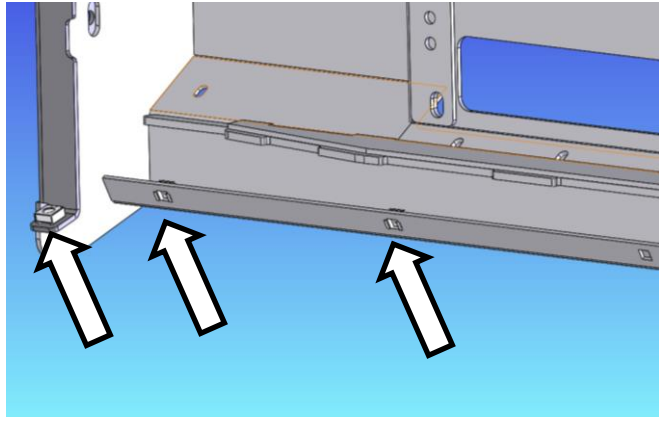

103. Fit 4x M6 cage nuts to bull bar lower lip on top face and 1x M8 cage nut to each mount.

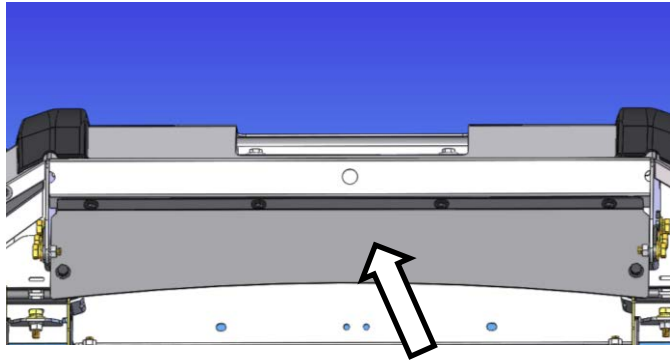

104. Fit stone guard to bar/ mounts using 4x M6x25mm BTN HD screws, M6 washers and M6 spring washers as well as 2x M8x1.25x25mm bolts, M8 washers and M8 spring washers.

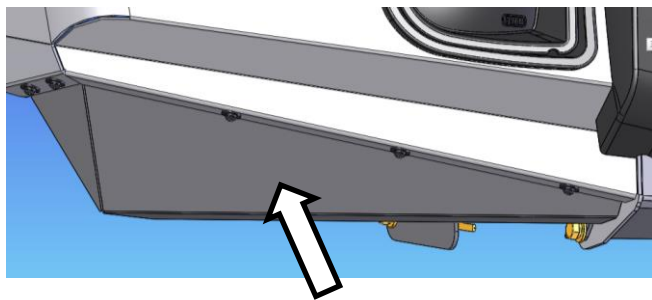

105. Fit wing under panels to bull bar using 10x M6x25mm BTN HD screws, M6 washers and M6 spring washers.

FITTED PRODUCT – MITSUBISHI PAJERO NX DELUXE BULL BAR

