



FITTING INSTRUCTIONS

PART NUMBER AND DESCRIPTION:

3638050 – SUMMIT REAR STEP TOW BAR (RSTB) WITHOUT FACTORY PARK SENSORS

3638060 – SUMMIT REAR STEP TOW BAR (RSTB) WITH FACTORY PARK SENSORS

SUITED TO VEHICLE/S:

NAVARA NP300 2015 ON

NOTE: For coil sprung vehicles, the spare wheel tyre diameter **must not** exceed 790mm. Ensure minimum clearance of 10mm between spare tyre and panhard rod after fitment.

WARNING

NOTE THE FOLLOWING:

- ◆ This product must be installed exactly as per these instructions using only the hardware supplied.
- ◆ In the event of damage to any tow bar component, contact your nearest authorised ARB stockist.
- ◆ Do not use this product for any vehicle make or model, other than those specified by ARB.
- ◆ Do not remove labels from this tow bar.
- ◆ This product or its fixing must not be modified in any way.
- ◆ The installation of this product may require the use of specialized tools and/or techniques
- ◆ It is recommended that this product is only installed by trained personnel.
- ◆ These instructions are correct as at the publication date. ARB Corporation Ltd. cannot be held responsible for the impact of any changes subsequently made by the vehicle manufacturer.
- ◆ During installation, it is the duty of the installer to check correct operation/clearances of all components.
- ◆ Work safely at all times.
- ◆ Unless otherwise instructed, tighten fasteners to specified torque.
- ◆ The eyelets on the rear bar have been designed and tested for connection of trailer safety chains. They are not to be used for recovery or direct towing.
- ◆ For recovery, fit a suitable and rated tow hitch to the central tow hitch receiver.
- ◆ Position high lift jack at lift locations beneath the middle of the wings and corner of the RSTB. Do not lift directly from the end of the wing.
- ◆ When using the tow hitch receiver, the centre panel should be in the raised position.

ARB 4x4 ACCESSORIES

Corporate Head Office

42-44 Garden St
Kilsyth, Victoria
AUSTRALIA 3137

Tel: +61 (3) 9761 6622
Fax: +61 (3) 9761 6807

Australian enquiries
North & South American enquiries
Other international enquiries

sales@arb.com.au
sales@arb.com.au
exports@arb.com.au

www.arb.com.au

GENERAL CARE AND MAINTENANCE

By choosing an ARB Bar, you have bought a product that is one of the most sought after 4WD products in the world. Your bar is a properly engineered, reliable, quality accessory that represents excellent value. To keep your bar in original condition it is important to care and maintain it following these recommendations:



- Prior to exposure to the weather your bar should be treated to a Canuba based polish on all exposed surfaces. It is recommended that this is performed on a six monthly basis or following exposure to salt, mud, sand or other contaminants.
- As part of any Pre Trip Preparation, or on an annual basis, it is recommended that a thorough visual inspection of the bar is carried out, making sure that all bolts and other components are torqued to the correct specification. Also check that all wiring sheaths, connectors, and fittings are free of damage. Replace any components as necessary. This service can be performed by your local authorized ARB Stockist.

FITTING REQUIREMENTS

REQUIRED TOOLS FOR FITMENT OF PRODUCT:

BASIC TOOL KIT	SIDE CUTTERS
INSULATION TAPE	70MM HOLE SAW BIT
6.5MM DRILL BIT	WIRE STRIPPER
DEUTSCH CRIMPING TOOL	POWER DRILL
NEEDLE NOSE PLIERS	SOCKET SET
ALLEN KEY SET	TAPE MEASURE
FINE ROUND FILE	RUST PREVENTATIVE PAINT
MASKING TAPE	SOLDERING IRON + SOLDER
HEAT SHRINK + HEAT GUN	

HAVE AVAILABLE THESE SAFETY ITEMS WHEN FITTING PRODUCT:

Protective eyewear		Hearing protection	
--------------------	---	--------------------	---

NOTE: 'WARNING' notes in the fitting procedure relate to OHS situations, where to avoid a potentially hazardous situation it is suggested that protective safety gear be worn or a safe work procedure be employed. If these notes and warnings are not heeded, injury may result.

FASTENER TORQUE SETTINGS:

SIZE	Torque Nm	Torque lbft
M6	9 Nm	7 lbft
M8	22 Nm	16 lbft
M10	44 Nm	32 lbft
M12x1.75	77 Nm	57 lbft
M12x1.25	95 Nm	71 lbft

RSTB PARTS LISTING

APPLICATION	PART NO.	QTY	DESCRIPTION	
PREPARE REAR STEP TOW BAR (RSTB)	6523002	1	LIFT UP PANEL	
	5670026	2	SPRING EXT 11.25 OD x 43	
	6602011	2	CANOE CLIP BLACK	
	6151256	2	SCREW BTN HD M6 x 16 SS	
	6151549	2	NUT NYLOC M6 x 1.0 GR8.8 BTZP480	
	4584295	4	WASHER FLAT M6 x 12 x 1.3 BLK ZN	
RSTB TO VEHICLE	6151096	14	BOLT HXHD M12 x 1.25 x 40 CL8.8 ZP	
	4581050	14	WASHER SPRING 1/2 x 3/16 x 3/16 ZP	
	4581007	14	WASHER FLAT 1/2 x 1 1/2 x 4 SILVER TZP	
BEAVER PANEL TO VEHICLE	6523034	1	BEAVER PANEL NAVARA	
	3194833	1	PLATE 10MM SPANNER	
	3759642	1	LICENSE PLATE MOUNT	
	3759923R	1	LICENSE PLATE BRACKET RH	
	3759923L	1	LICENSE PLATE BRACKET LH	
	6151256	6	SCREW BTN HD M6 x 16 SS	
	6151213	4	BOLT M6 x 1.0 x 20 Gd8.8 BZ	
	6151295	2	SCREW BTN HD M8 x 20 SS	
	4581287	2	WASHER SPRING M6 x 2.5 x 1.6 BLK ZN	
	4581082	2	WASHER FLAT, M6 x 19 x 1.6 BZ	
	4581304	6	WASHER FLAT M6 SS	
	4584295	12	WASHER FLAT M6 x 12 x 1.3 BLK ZN	
	4581081	2	WASHER FLAT M8 SS	
	6151549	10	NUT NYLOC M6 x 1.0 GR8.8 BTZP480	
5848302	2	PACKER RB NYLON		
STEP PLATE TO RSTB	3194759	1	STEP PLATE EXTRUSION NAVARA	
	3163125	1	LIGHT BEZEL MOULDING	
	3759536	1	LED MOUNT BRACKET	
	6151256	8	SCREW BTN HD M6 x 16 SS	
	6151715	16	NUT M6 CAGED 3.6-4.5mm 836-D	
	6821270	1	NARVA 90810 LED LAMP KIT	
	6821116	2	PLASTIC SNAP-IN SMALL GROMMET	
PREPARE RSTB/VEHICLE FOR PANELS	3789381	1	TEMPLATE RSTB NAVARA WING	
	3759635R	1	WING MOUNT BRKT NAVARA RH	
	3759635L	1	WING MOUNT BRKT NAVARA LH	
	3759636R	1	WING MOUNT STRUT NAVARA RH	
	3759636L	1	WING MOUNT STRUT NAVARA LH	
	3194723	2	WING DOUBLE NUT PLATE	
	3194724	2	WING TRIPLE NUT PLATE	
	4581048	2	WASHER SPRING M10 TZP480	
	6151022	6	BOLT M8 x 1.25 x 25 Gd 8.8 ZP	
	4581063	6	WASHER FLAT M8 x 25 x 3 GOLD ZN	
	4581046	6	WASHER SPRING M8 x 3/32 x 3/32	
	FOR REAR COIL SPRUNG VEHICLES:			
	6151204	2	BOLT M10 x 1.5 x 35 Gd 8.8 ZP	
	4581040	2	WASHER FLAT M10 x 25 x 3 ZP	
	6151302	2	NUT CAGED M10 1.8-3.2	
3199943	2	CAGE PLATE 225mm		

RSTB PARTS LISTING

PANELS TO RSTB/VEHICLE	6151022	12	BOLT M8 x 1.25 x 25 Gd 8.8 ZP
	4581063	20	WASHER FLAT M8 x 25 x 3 GOLD ZN
	4581046	4	WASHER SPRING M8 x 3/32 x 3/32
	6151032	8	NUT NYLOC M8 x 1.25
	4581082	2	WASHER FLAT, M6 x 19 x 1.6 BZ
	6151213	2	BOLT M6 x 1.0 x 20 Gd8.8 BZ
	6151256	8	SCREW BTN HD M6 x 16 SS
	4581304	8	WASHER FLAT M6 SS
	4584295	2	WASHER FLAT M6 x 12 x 1.3 BLK ZN
	6151549	2	NUT NYLOC M6 x 1.0 GR8.8 BTZP480

FOR VEHICLES FITTED WITH PARKING SENSORS			
	3131513R	1	NAVARA WING RH
	3131513L	1	NAVARA WING LH
	6523035	1	NAVARA DIFFUSER PANEL RH
	6523036	1	NAVARA DIFFUSER PANEL LH
FOR VEHICLES WITHOUT PARKING SENSORS			
	3131512R	1	NAVARA WING RH
	3131512L	1	NAVARA WING LH
	6523032	1	NAVARA DIFFUSER PANEL RH
	6523033	1	NAVARA DIFFUSER PANEL LH
TOW TONGUE	4761170	1	TOW TONGUE 45 DEG
	55010	1	TOW BAR PULL PIN
	55020	1	SPRING CLIP
	180302	10	CABLE TIE 200mm

TRAILER WIRING

The following trailer wiring solutions can be purchased from ARB. Purchase the main wiring harness with ECU (Part no. 3600010) in conjunction with the appropriate socket and tail listed below. Alternatively, this product is compatible with the factory trailer wiring solution.

To install this loom, a crimping tool suitable for crimping contact type size 16 Deutsch pins is required. Suitable crimping tools can be purchased from auto electrical wholesalers as shown.



APPLICATION	PART NO.	QTY	DESCRIPTION
TRAILER WIRING	3600010	1	RSTB WIRING INCLUDING ECU
	3600020	1	RSTB SOCKET & TAIL 7 PIN FLAT
	3600030	1	RSTB SOCKET & TAIL 12 PIN FLAT
	3600040	1	RSTB SOCKET & TAIL 7 PIN ROUND LRG
	3600050	1	RSTB SOCKET & TAIL 7 PIN ROUND SML

OPTIONAL ACCESSORIES

The following ARB accessories can be fitted to this product:

APPLICATION	PART NO.	QTY	DESCRIPTION
OPTIONAL ACCESSORIES	171403	1	ARB AIR LINE FITTING
	10600030	1	ARB TRAILER CAMERA KIT
	58X22/A	1	RECOVERY HITCH AND SHACKLE
	6594050	1	50 AMP ANDERSON PLUG



AIR LINE FITTING



TRAILER CAMERA KIT



RECOVERY HITCH



ANDERSON PLUG

GENUINE ACCESSORIES REMOVAL

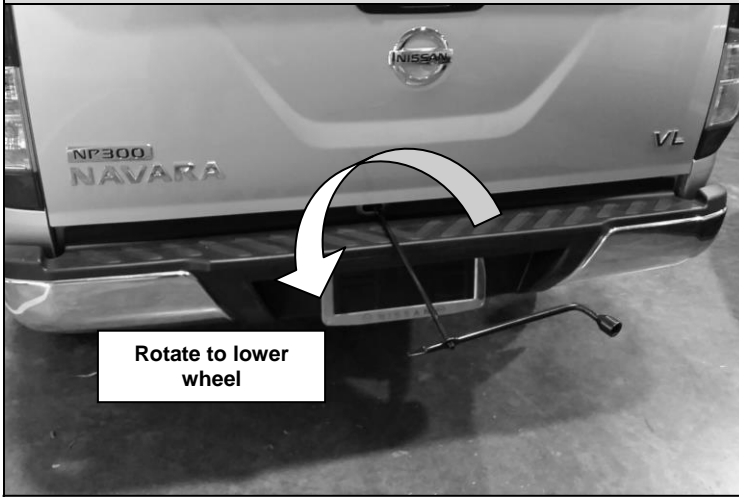

1. Remove the spare wheel from beneath the tub using the wheel nut wrench and jack handle pieces supplied with the vehicle. Insert as shown through the access slot above the number plate and rotate counter-clockwise to release the wheel.

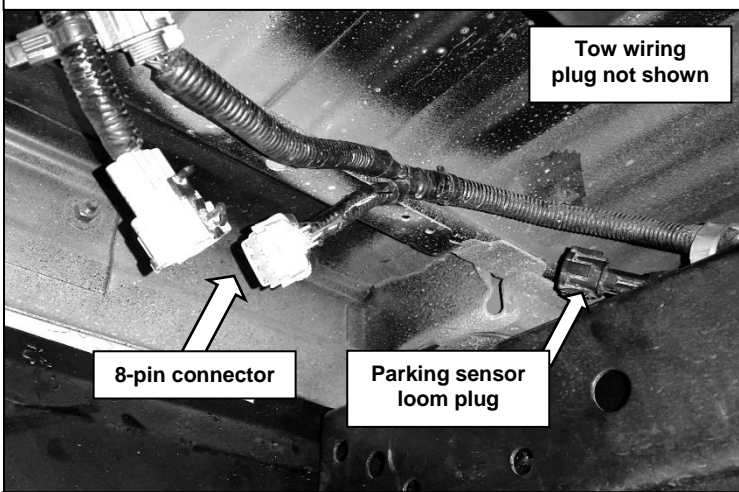

For vehicles fitted with parking sensors and/or a trailer plug:

2. Disconnect the parking sensor and/or tow wiring looms from the vehicle loom at the locations shown.
3. Disconnect the 8-pin connector as shown.

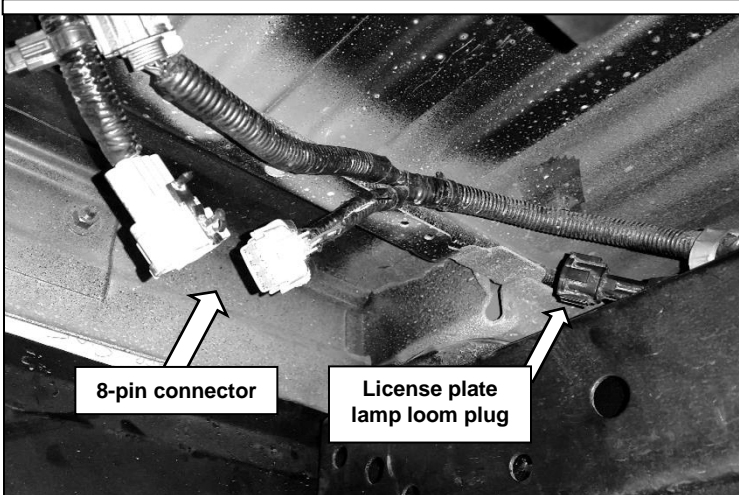

For vehicles fitted without parking sensors:

4. Disconnect the licence plate lamp and/or tow wiring looms from the vehicle loom at the location shown.
5. Disconnect the 8-pin connector as shown.



For vehicles fitted with a tow bar:

6. Remove the factory tow bar from the vehicle by removing the M12 bolts from each chassis rail.
7. Disconnect the trailer plug from the tow bar by removing the loom fasteners. Place the plug to the side where it will not be damaged during fitment of the Rear Step Tow Bar (RSTB).

GENUINE ACCESSORIES REMOVAL

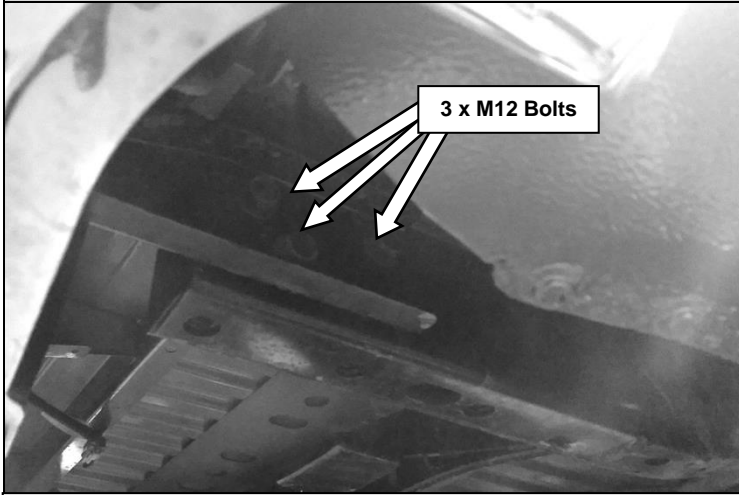

8. Remove the bumper bar from the vehicle by removing 3 M12 bolts from each chassis rail as shown.



For vehicles fitted without parking sensors:

9. Cut the license plate lamp loom at the point indicated in the photo and set loom with connector aside for later use.



For vehicles fitted with parking sensors:

10. Carefully unplug the parking sensor loom from the 4 parking sensors in the bumper bar. Leave sensors and housings in the bumper bar at this stage.
11. Remove the parking sensor loom from the bumper bar by removing 7 loom fasteners.

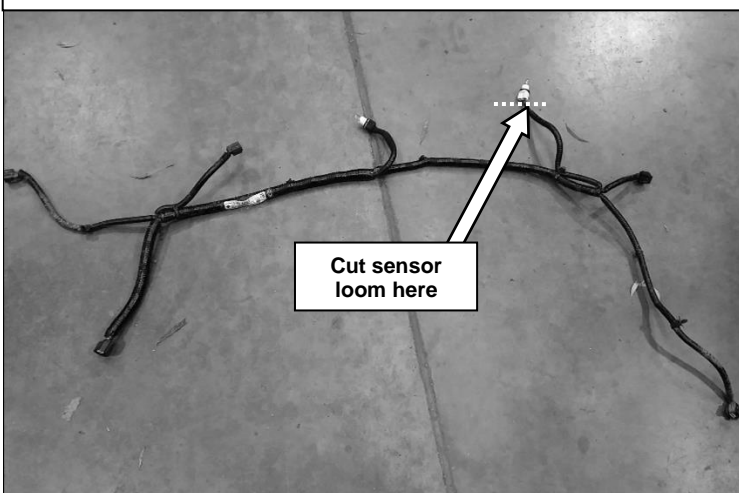

For vehicles fitted with parking sensors:

12. Cut the sensor loom just before the license plate light at the point indicated in the photo and set loom aside for later use.

Warning: Ensure vehicle lights are turned off before cutting wires.

VEHICLE/RSTB WIRING

A trailer wiring solution that incorporates a smart ECU is available for this vehicle. To fit this solution, the rear vehicle wiring harness must be cut and high quality, waterproof Deutsch connectors installed to provide signal pickup points for the ECU.

To install this loom, a suitable crimp tool is required. Refer to Page 4 for more details about the crimp tool.

Follow the steps below to install the trailer wiring solution:

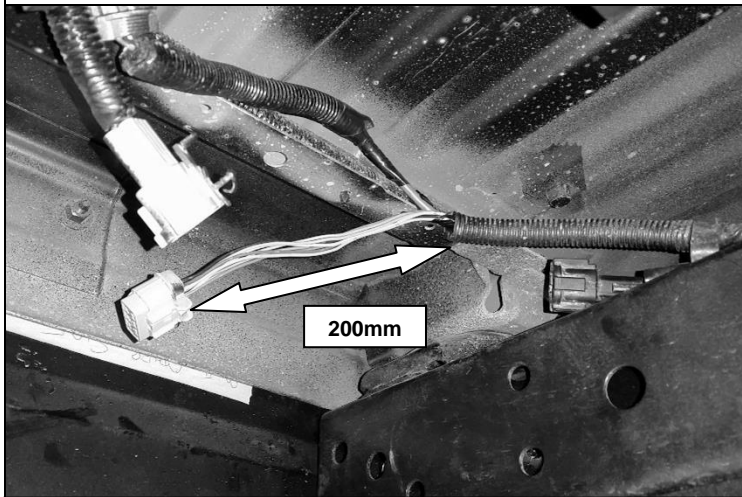

13. Locate the vehicle loom on the inside of the rear panel near the left chassis rail as shown. Remove 200mm of tape and corrugated tubing if present from behind the 8-pin connector as shown.

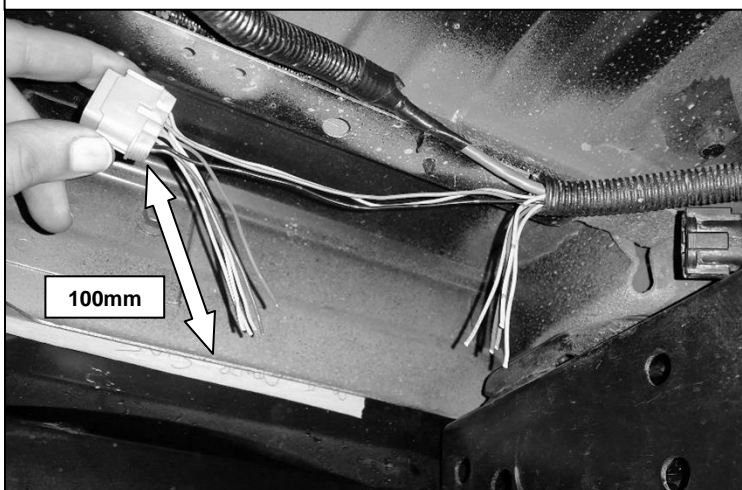

14. Cut the following coloured wires at a distance of 100mm from the connector as shown:

Dark Blue
Light Blue
Pink
Yellow
Green

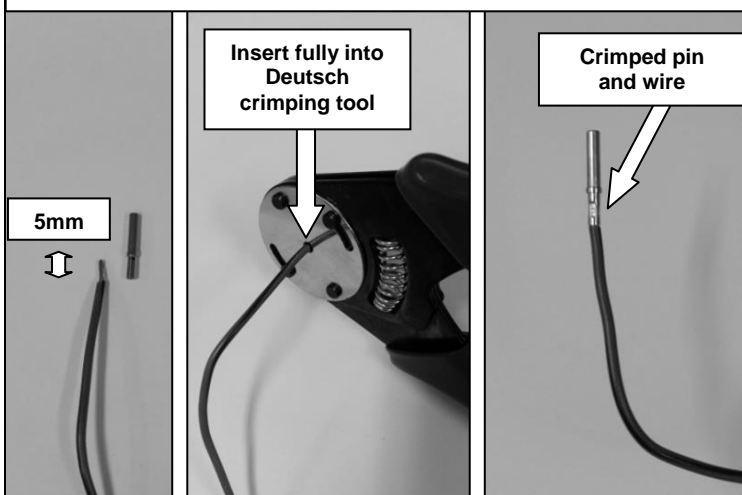

15. Remove 5mm of the plastic insulation coating from the end of each newly cut wire.
Note: For thin wires, consider exposing 10mm of copper and fold back on itself to increase thickness for a better crimp connection.

16. Insert each wire into the shorter end of a metal Deutsch pin.

17. Insert the longer end of the metal Deutsch pin into a crimping tool and crimp the wire and pin together as shown.

VEHICLE/RSTB WIRING

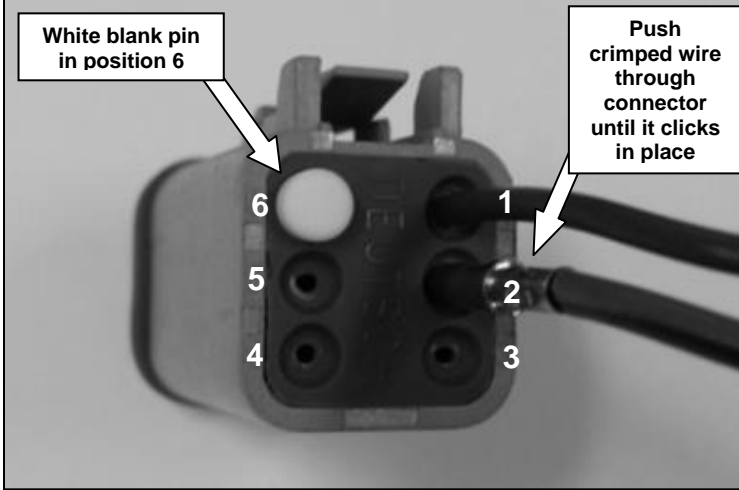

18. Insert one set of wires into a male 6-pin connector from the back in the following order:

Pin position	Wire colour
1	Pink
2	Light Blue
3	Green
4	Yellow
5	Dark Blue

Note: Pin positions are shown on the back of the connector.

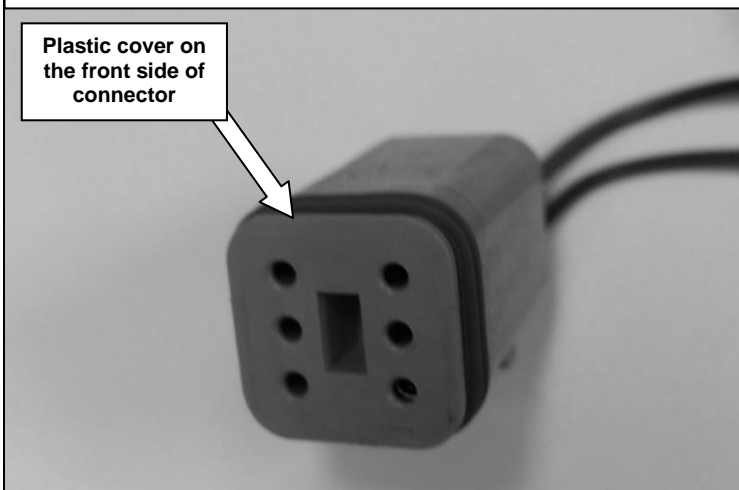

19. Insert the white blank pin into position 6 as shown in the previous step.
20. Insert the plastic cover to the front of the connector as shown.

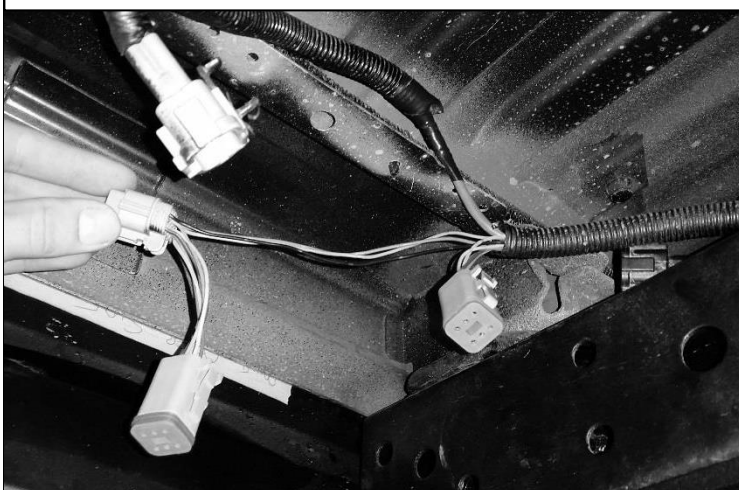

21. Repeat steps 18-20 for the other connector.

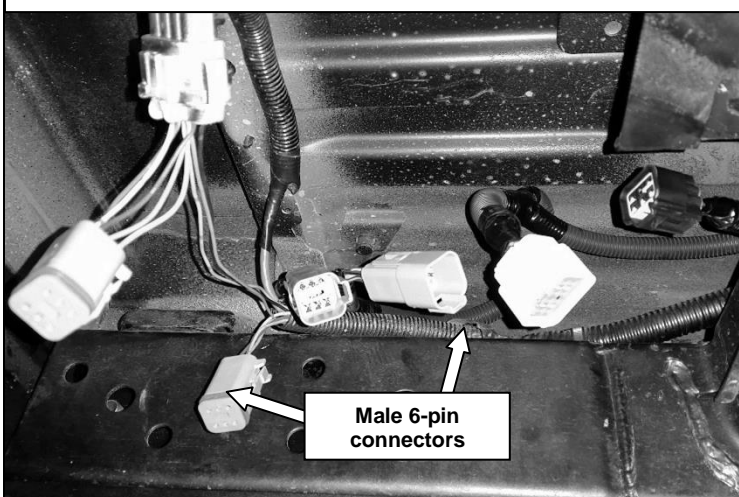

22. Place the RSTB wiring harness on top of the left chassis rail as shown.
23. Position the RSTB wiring harness so the connectors are located towards the rear and the positive supply wire towards the front of the vehicle.

VEHICLE/RSTB WIRING

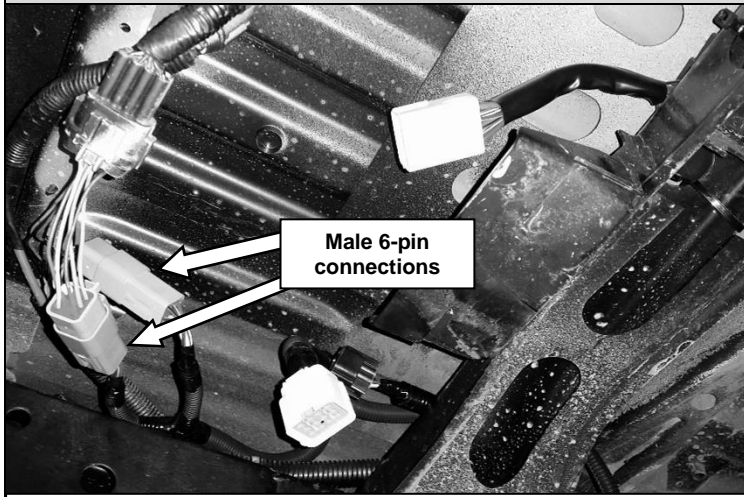

24. Connect the RSTB wiring harness to the 2 male 6-pin connectors.

Note: The RSTB wiring harness is not polarity sensitive in this region so the male 6-pin connectors can be connected to either female connector.

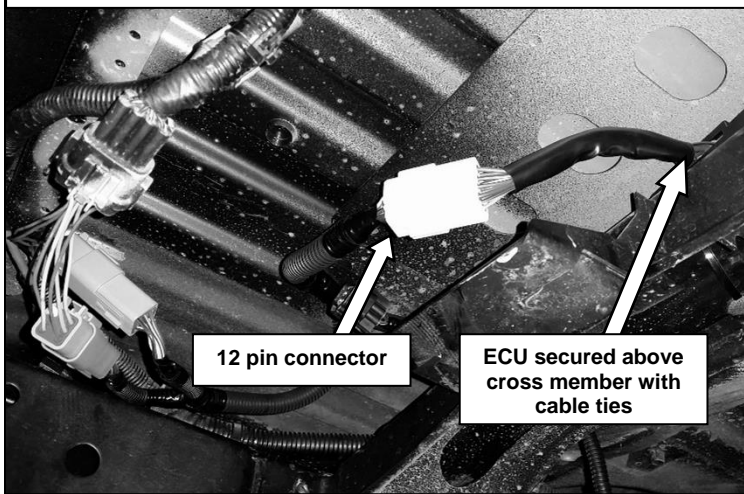

25. Position the ECU on top of cross member beneath tub as shown. Secure using the ECU mounting holes and cross member holes with 2 cable ties.

26. Connect the ECU unit to the RSTB wiring harness using the large 12 pin connector.

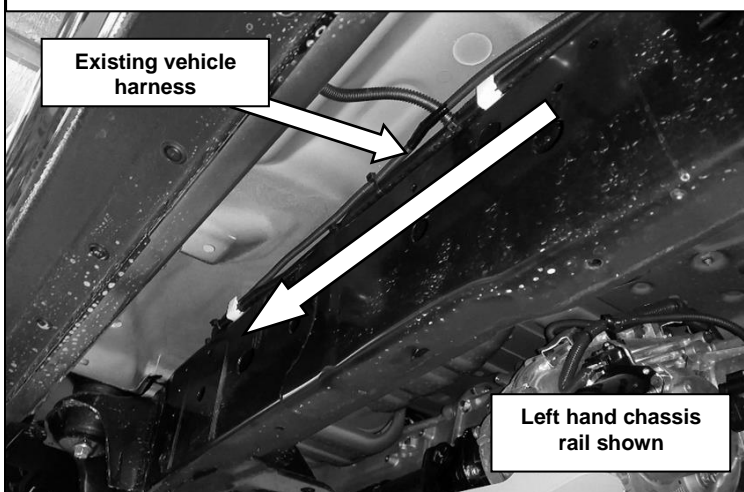

27. Route the positive supply wire to the front of the vehicle following the existing vehicle harness along the left chassis rail.

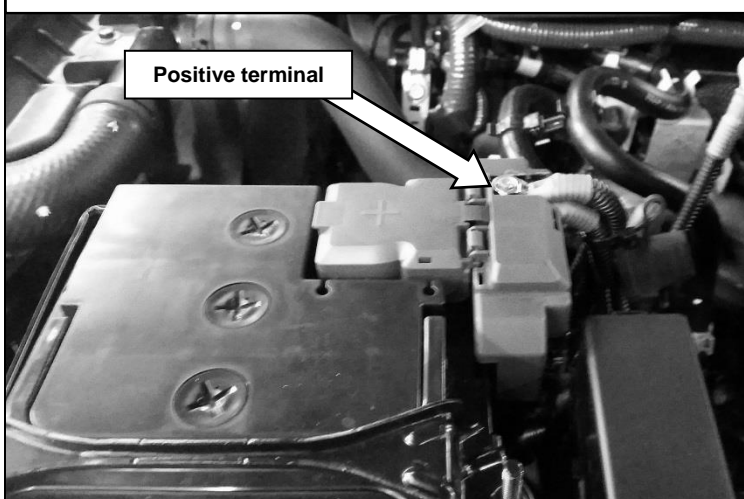

28. Continue routing the positive supply wire through the engine bay to the battery.

29. Connect the positive supply wire to the positive terminal of the battery using the existing bolt as shown.

VEHICLE/RSTB WIRING

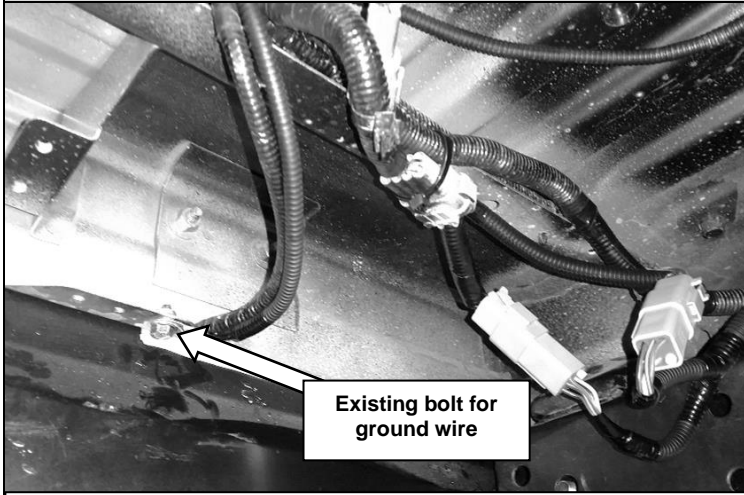

30. Connect the ground wire of the RSTB harness to the bolt on the inside of the rear vehicle panel as shown.
31. Ensure vehicle tail lights function correctly.
32. Re-wrap the exposed wires with the existing split corrugated tubing and new tape.

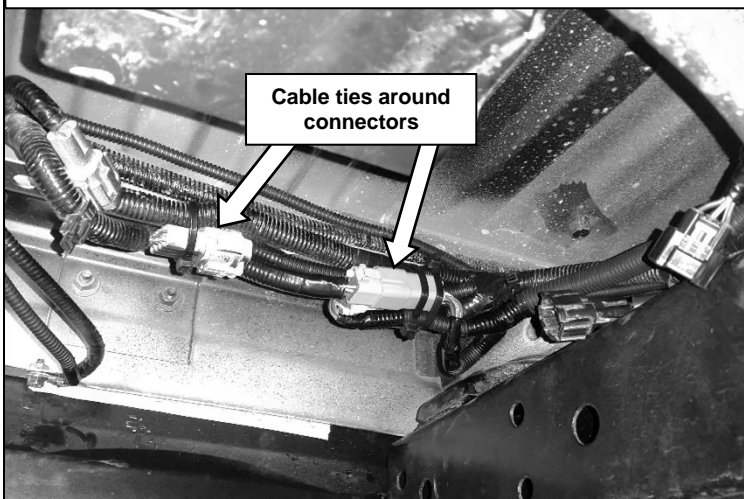

33. Tidy and fasten all wiring using the cable ties provided.

Warning: Make sure all wires are securely fastened away from any hot, sharp or moving surfaces. Do not fasten wiring harness to fuel or brake lines.

34. Ensure vehicle tail lights function correctly.

PREPARE REAR STEP TOW BAR (RSTB)

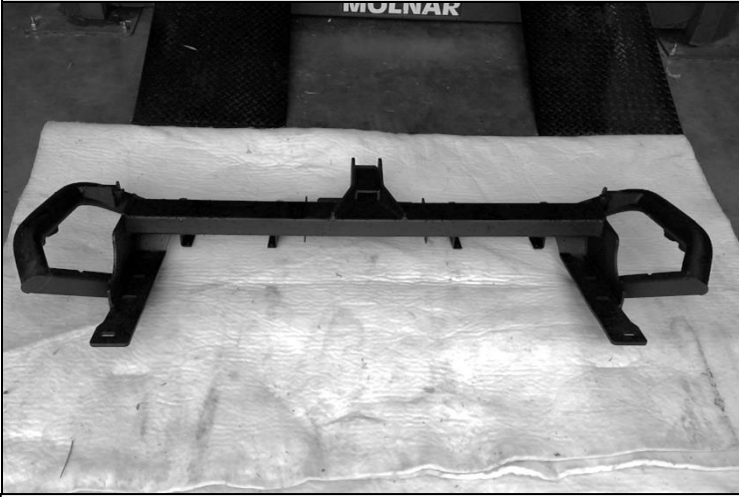

35. Place the RSTB on a flat surface that will not damage its coating as shown.

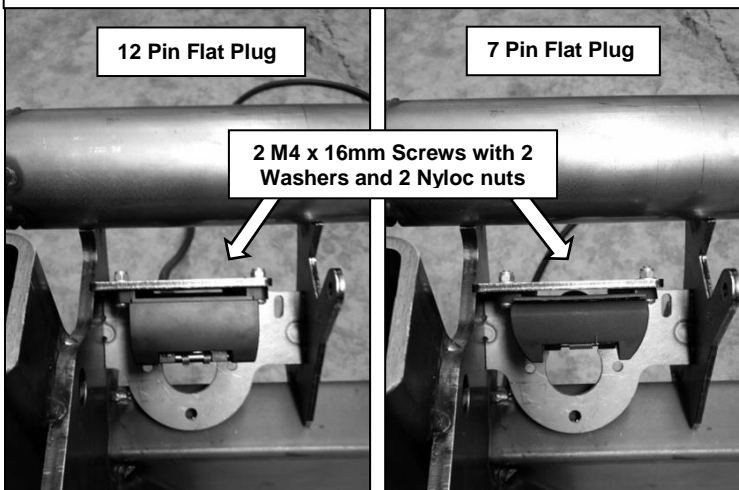

For fitment of flat trailer plugs:

36. Using the appropriate mounting holes as shown and fasteners supplied with the trailer plug, attach the trailer plug to the trailer plug bracket on the RSTB.

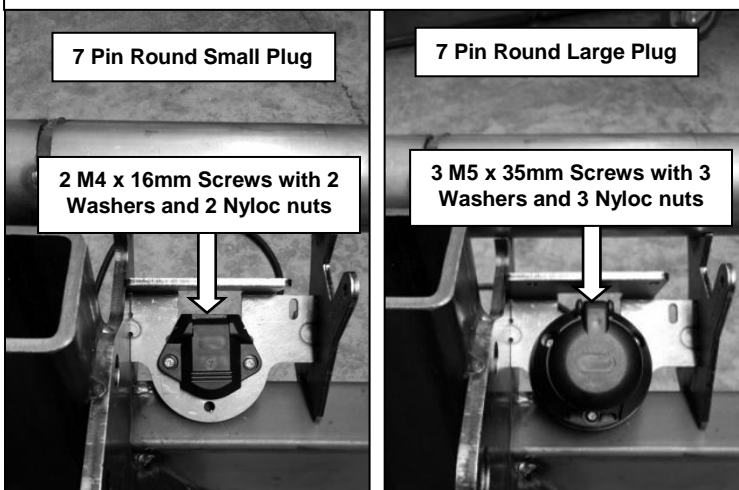

For fitment of round trailer plugs:

37. Using the appropriate mounting holes as shown and fasteners supplied with the trailer plug, attach the trailer plug to the trailer plug bracket on the RSTB.

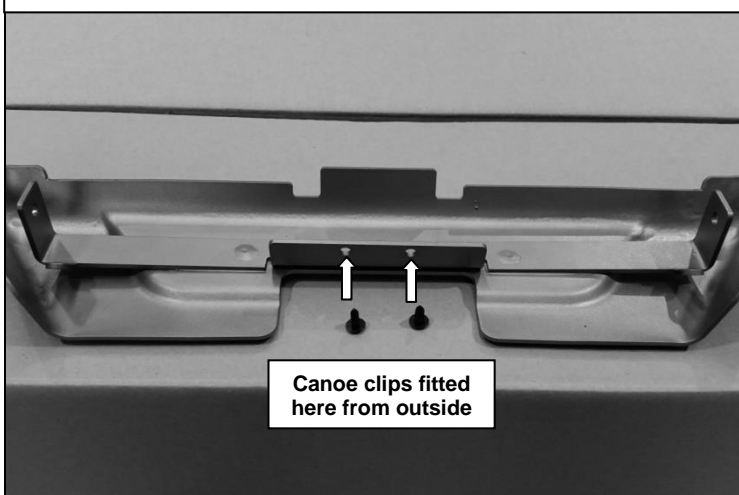

38. Fit 2 plastic canoe clips to the lift up panel using the holes as shown.

PREPARE REAR STEP TOW BAR (RSTB)

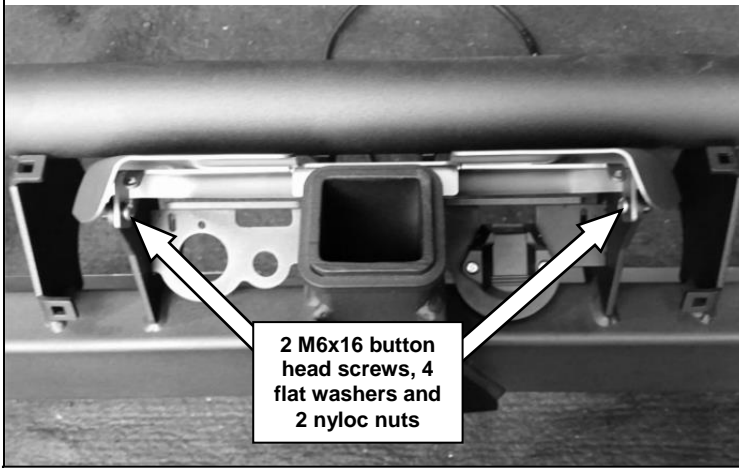

1. Attach the lift up panel to the pivot plates on the RSTB using 2 M6x1.0x16 button head screws, 4 M6 flat washers (black) and 2 M6 nyloc nuts.
2. Tighten the screws enough to ensure the lift up panel is centralised with minimal sideways movement, but still able to lift up and down freely.

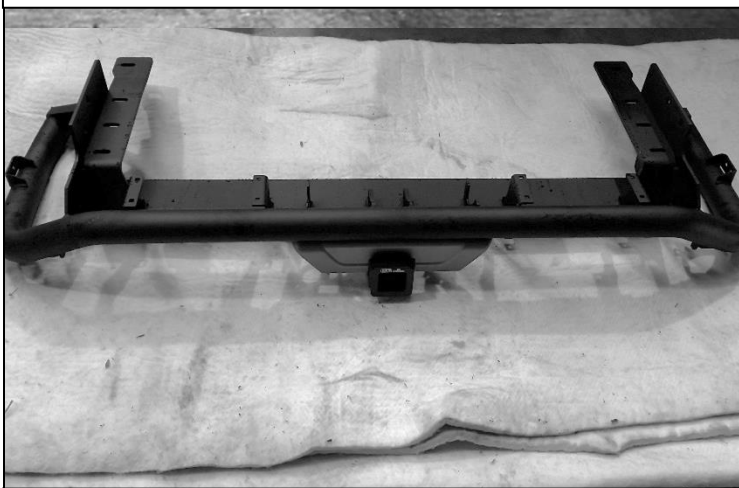

39. Rotate the RSTB 180° so it is now resting flat on the ground as shown.

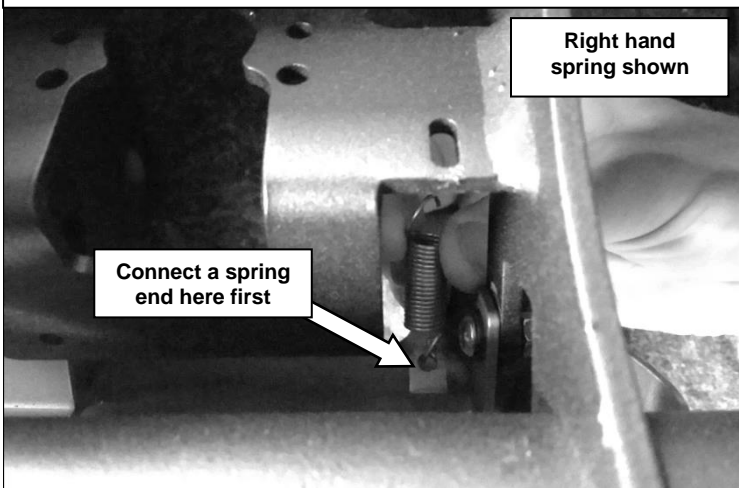

40. Connect 2 springs between the RSTB and lift up panel. From above, first connect one end of each spring to the lift up panel as shown.

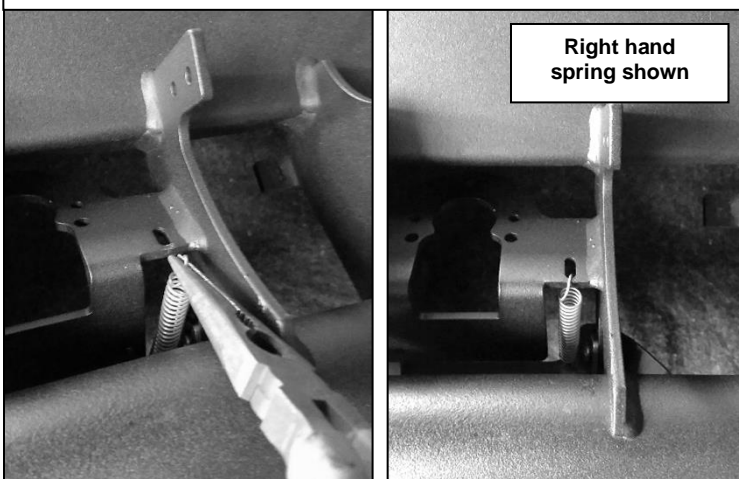
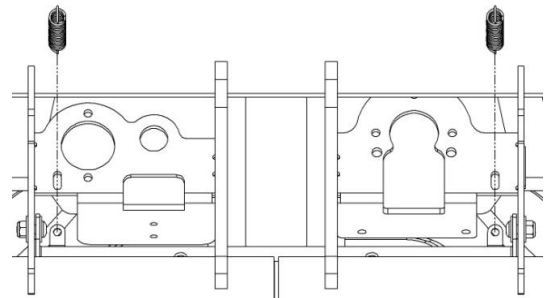

41. Using pliers, stretch the free end of each spring up to the bracket on the RSTB as shown.



Warning: Safety glasses should be worn for this operation as the spring may slip off the pliers if not clamped tightly.

RSTB TO VEHICLE



42. With the assistance of other people or a lifting device, lift the RSTB up beneath the chassis rails aligning the threaded holes in the side of the chassis with those in the vertical surfaces of the RSTB.

Note: Take care to ensure the trailer plug wiring is not damaged during this step.

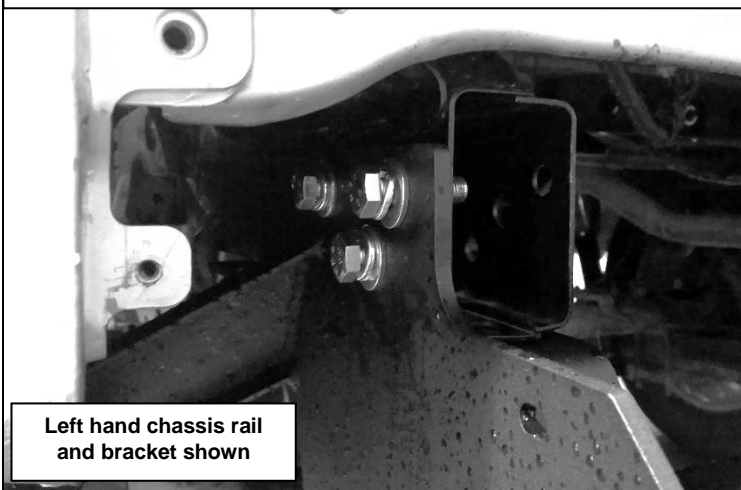

Left hand chassis rail and bracket shown

43. Fix the vertical plates of the RSTB to the threaded holes in each chassis rail using 3 M12x1.25x40 (fine pitch) hex head bolts, 3 M12 spring washers and 3 M12 flat washers per chassis rail. Leave finger tight at this stage.

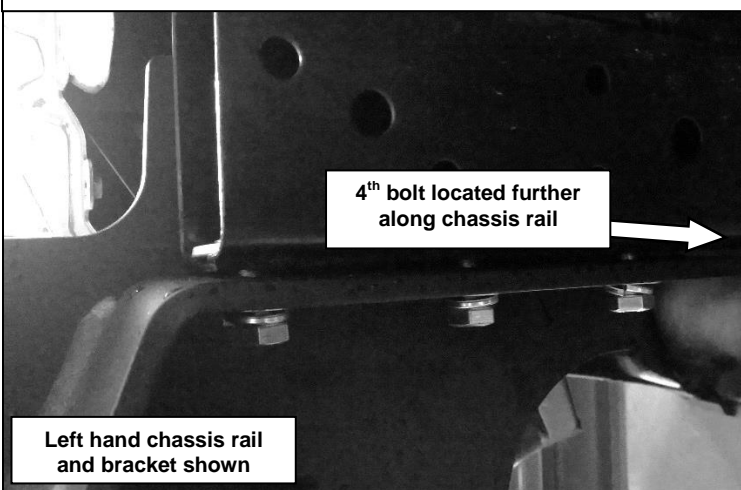

4th bolt located further along chassis rail

Left hand chassis rail and bracket shown

44. Fix the horizontal plates of the RSTB to the threaded holes in each chassis rail using 4 M12x1.25x40 (fine pitch) hex head bolts, 4 M12 spring washers and 4 M12 flat washers per chassis rail. Leave finger tight at this stage.



45. Position the bar so there is even spacing to the vehicle and tighten all fasteners to the specified torque.



M12 X 1.25 - 95 Nm.

BEAVER PANEL TO RSTB

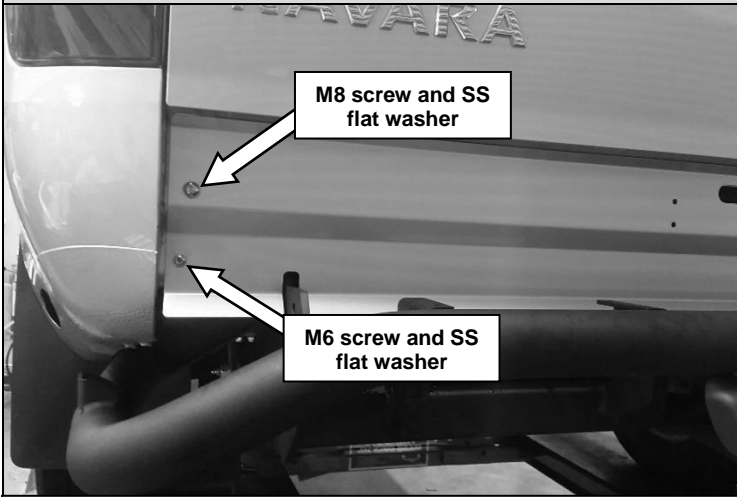

46. Fix the beaver panel to the vehicle using the 4 existing weld nuts, 2 M8x1.25x20 button head screws, 2 M6x1.0x16 button head screws, 2 M8 flat washers (SS) and 2 M6 flat washers (SS) as shown.

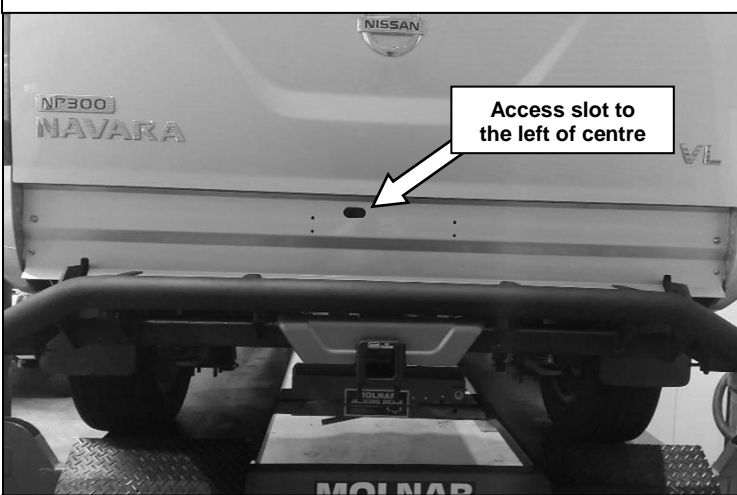

47. Position the panel so there is even spacing around edges and align the slot in the middle with the existing slot in the rear vehicle panel.

48. Tighten all fasteners to the specified torque.



M6 X 1.0 - 9 Nm.



M8 X 1.25 - 22 Nm.

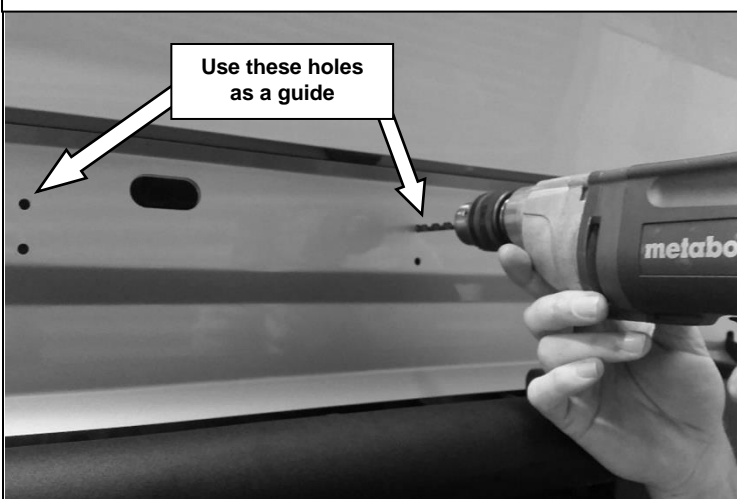

49. Using the top mounting holes in the middle of the beaver panel as a guide, drill 2 holes through the rear vehicle panel as shown using a Ø6.5mm drill bit.



50. De-bur each hole to remove sharp edges and treat raw edges with a rust preventative paint.

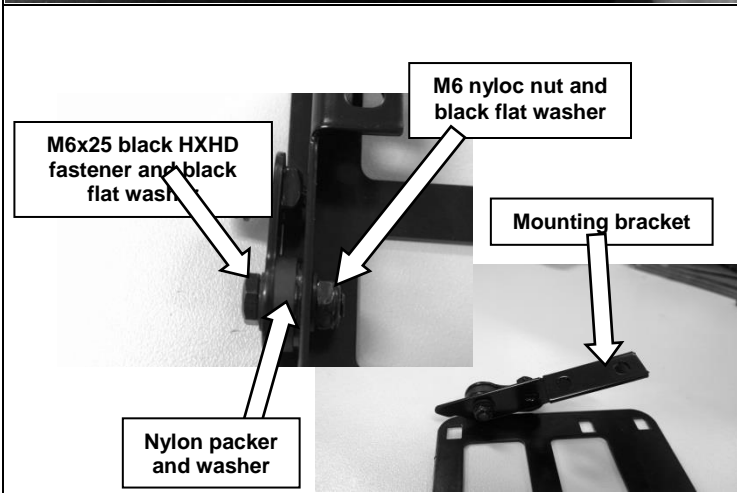

51. Assemble license plate bracket as shown taking note of mounting bracket orientation. Repeat step for opposite side of license plate bracket.

52. Tighten the screws enough so the brackets can be rotated by hand but not freely by themselves.

BEAVER PLATE TO RSTB

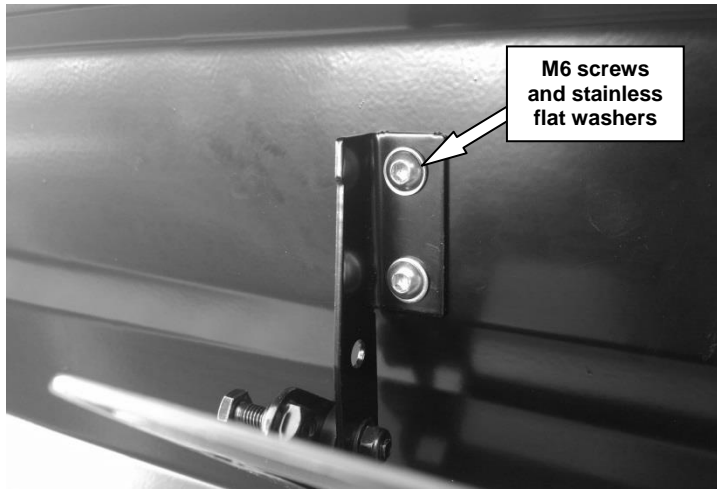

51. Fix the license plate assembly to the beaver panel using 4 M6x1.0x16 button head screws, 4 M6 flat washers (black), 4 M6 flat washers (SS) and 4 M6 nyloc nuts as shown.

52. Tighten all screws to the specified torque.



M6 X 1.0 - 9 Nm.

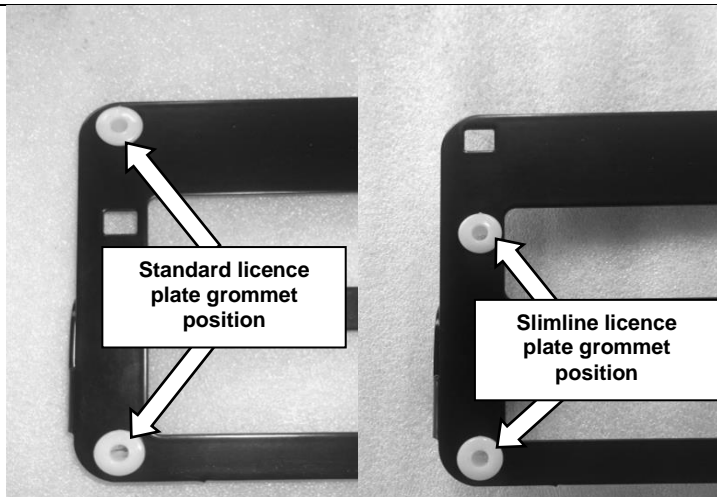

53. Insert 4 plastic grommets into number plate frame to suit licence plate size



54. Using 4 screws supplied fasten licence plate to frame.

55. Screw in partially 2 M6 X 20 black hexhead fastener along with black M6 washer and spring washer into upper hole of licence plate frame (both sides).

Note: These fasteners are used to stop licence plate frame from rotating to an open position when the vehicle is in motion.

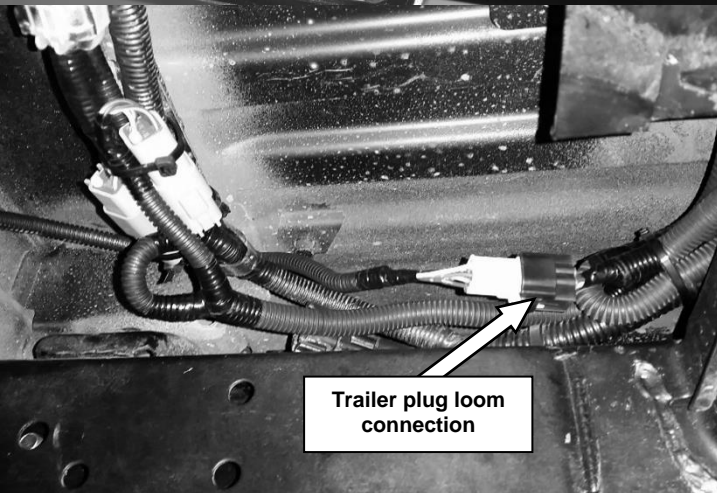

56. Route the trailer plug loom through the RSTB and attach to the appropriate connector on the RSTB wiring harness or vehicle loom as shown.

57. Ensure all trailer tail lights function normally.

Note: Test that the trailer park, brake and reverse lights function normally. Also test the left and right indicators along with the hazard setting.

STEP PLATE TO RSTB

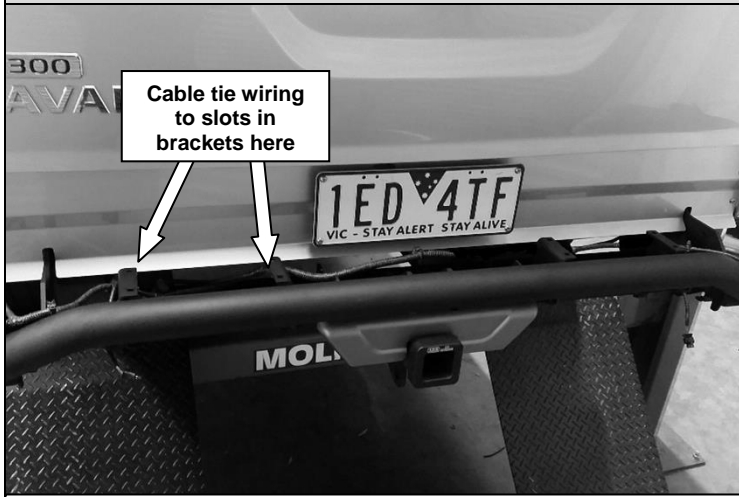

58. Tidy and fasten all wiring using cable ties and the slots in the RSTB brackets, as well as existing fastening locations.

Warning: Make sure all wires are securely fastened away from any hot, sharp or moving surfaces. Do not fasten wiring harness to fuel or brake lines.

59. Ensure trailer tail lights function normally as per step 67.

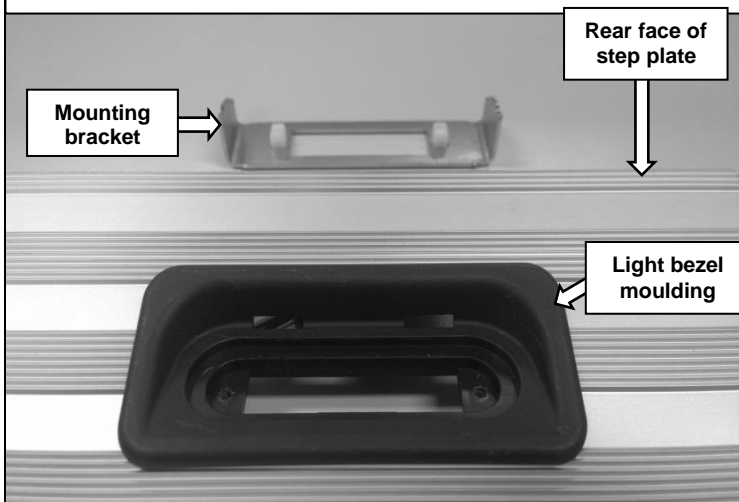

60. Push 2 plastic snap-in small grommets through the 2 holes in the LED mounting bracket as shown. Install the grommets from the underside of the bracket.

61. Fit the light bezel moulding to the step plate extrusion as shown with the deep section facing towards the rear face of step plate.

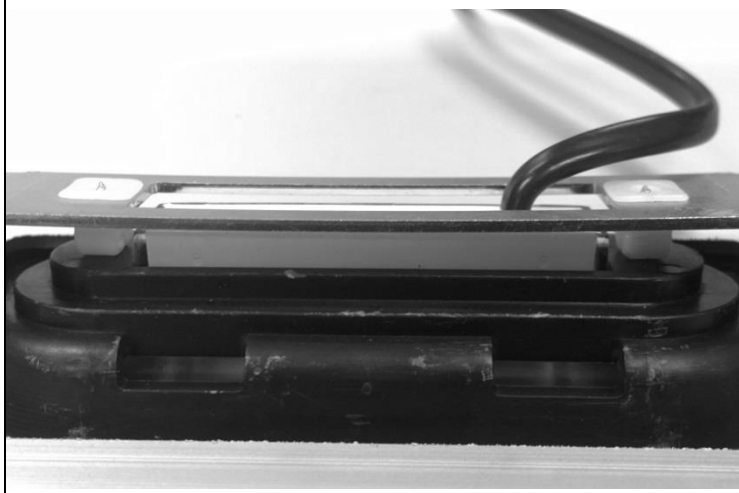

62. **Remove the foam ring from the LED lamp and discard.**

63. Place the LED lamp in the light bezel moulding and fix to the mounting bracket using the screws supplied in the lamp kit.

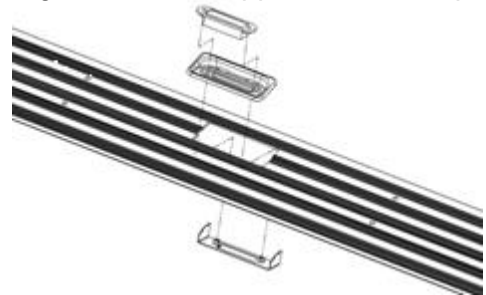

64. Fit the clear plastic plugs supplied in the lamp kit to the LED lamp above the screws.

STEP PLATE TO RSTB

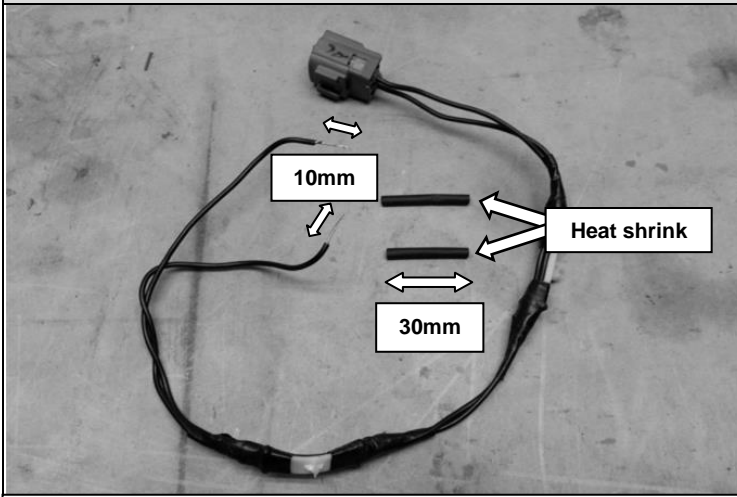

For vehicles fitted without parking sensors:

65. Remove 10mm of the plastic insulation coating from the license plate lamp loom at the point that was cut and set aside in step 9.
66. Insert a 30mm piece of heat shrink over each wire as shown.

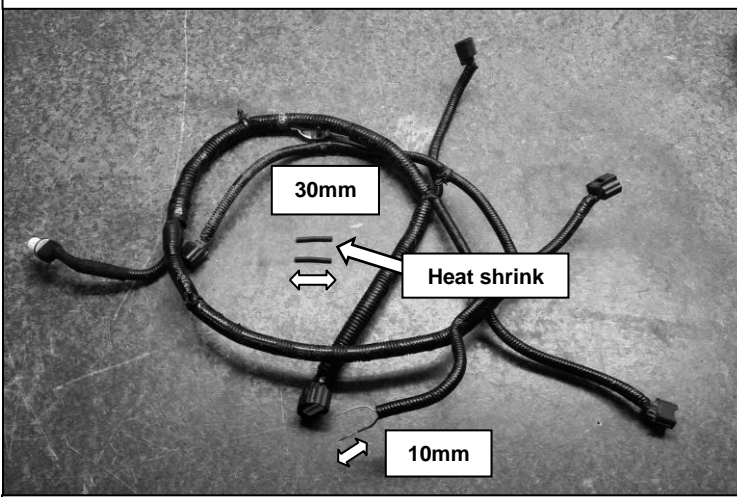

For vehicles fitted with parking sensors:

67. Remove 10mm of the plastic insulation coating from the sensor loom at the point that was cut and set aside in step 12.
68. Insert a 30mm piece of heat shrink over each wire as shown.

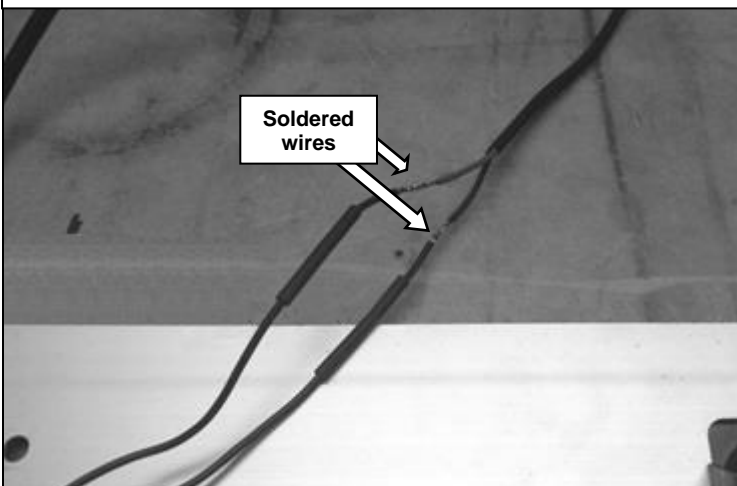

69. Using a soldering iron and solder, join the LED lamp wires to the license plate lamp or sensor loom using the colours in the table below:

LED Lamp wire	License plate loom
Red	Blue
Black	Black

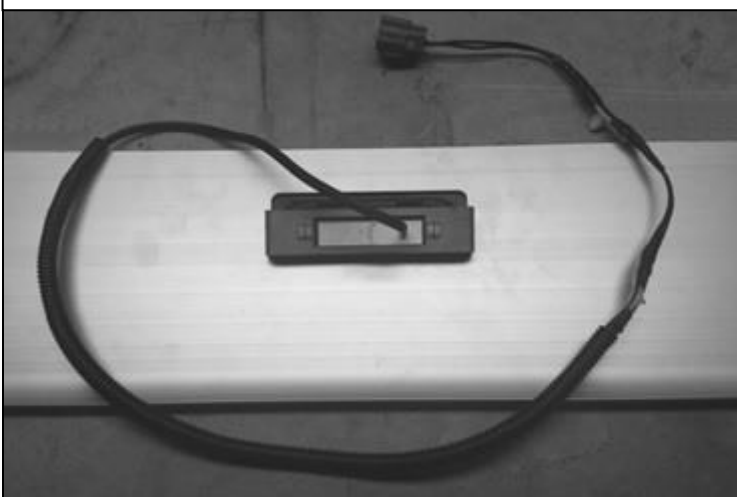

For vehicles fitted without parking sensors:

70. Place the heat shrink over the soldered wires and use a heat gun to shrink in place.
71. Further protect each join with corrugated tubing and insulation tape.

STEP PLATE TO RSTB

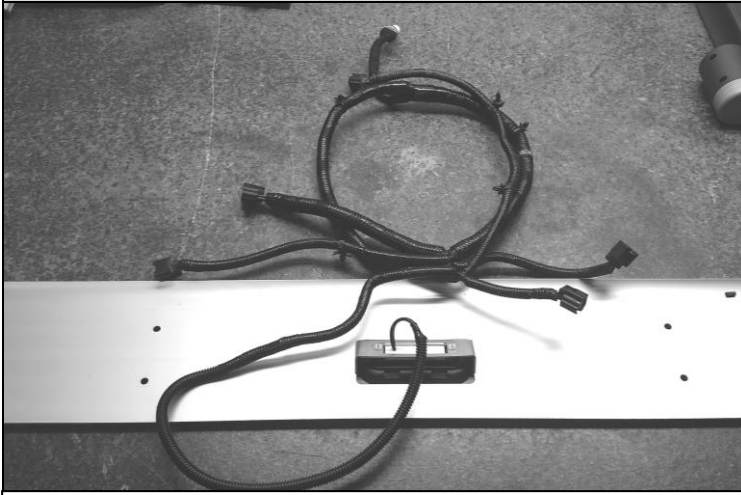

For vehicles fitted with parking sensors:

72. Place the heat shrink over the soldered wires and use a heat gun to shrink in place.
73. Further protect each join with corrugated tubing and insulation tape.

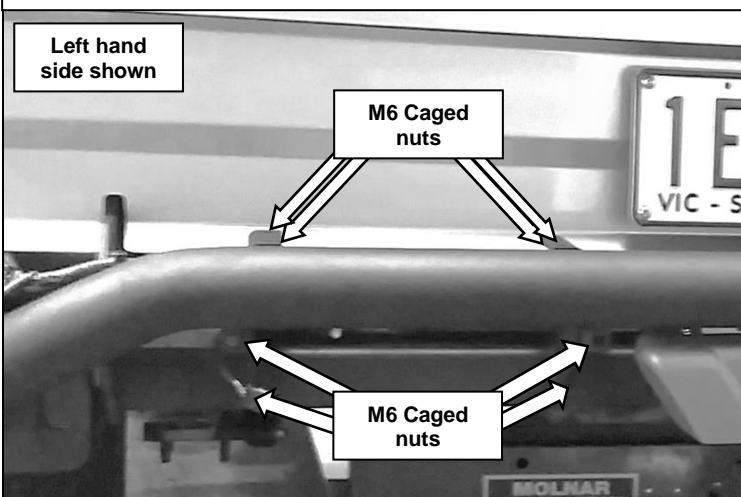

74. Fit 16 long-leg M6 caged nuts to the RSTB. Fit 8 caged nuts to the left hand side as shown and 8 caged nuts to the right hand side.

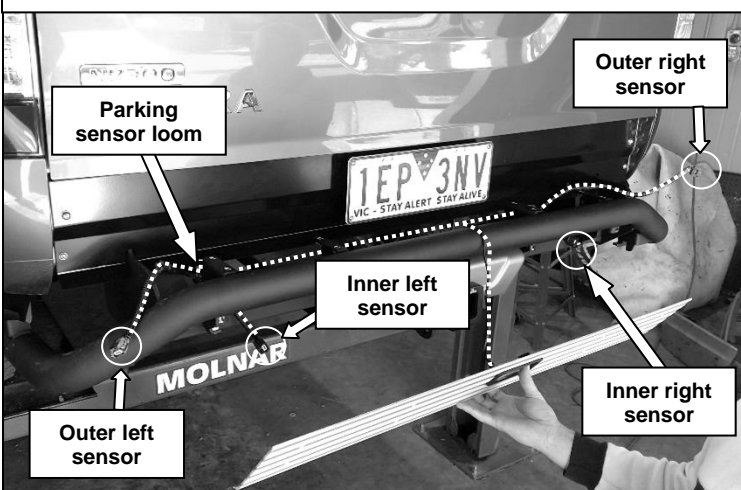

For vehicles fitted with parking sensors:

75. Route the parking sensor loom through the RSTB and position the parking sensor connectors in appropriate positions as shown.
76. Attach the parking sensor loom to the connector as identified in step 2.



77. Attach the step plate extrusion to the RSTB using 8 M6x1.0x16 button head screws taking care not to damage the LED lamp wire.

STEP PLATE TO RSTB

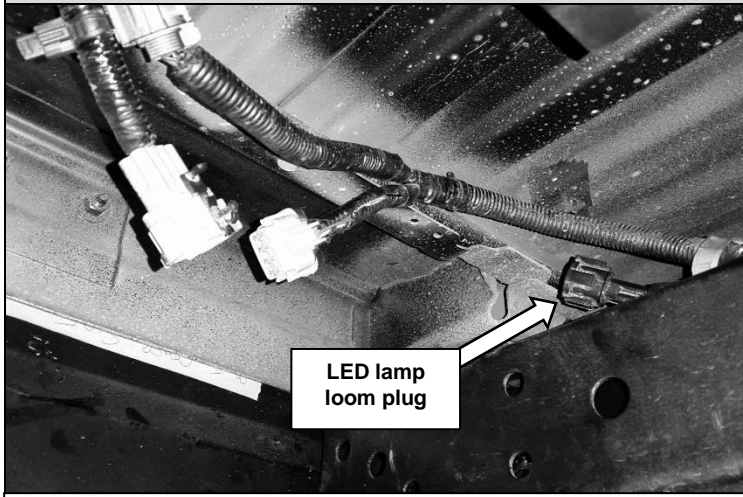

For vehicles fitted without parking sensors:

78. Route the LED lamp loom through the RSTB to its fastening point identified in step 4 and connect to the existing connector.
79. Ensure the license plate LED lamp functions correctly.



80. Tidy and fasten all wiring using the cable ties provided.

Warning: Make sure all wires are securely fastened away from any hot, sharp or moving surfaces. Do not fasten wiring harness to fuel or brake lines.

81. Test the LED lamp as per step 81 to confirm correct operation.

PREPARE RSTB/VEHICLE FOR PANELS

Right hand side shown

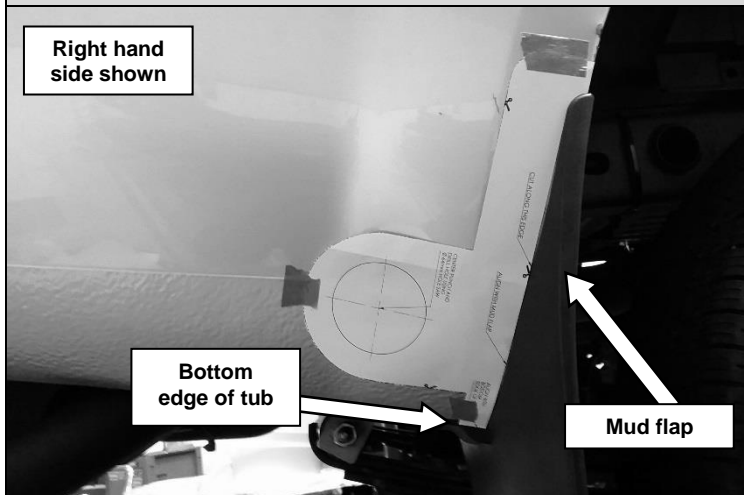

82. Place the cutting template on the right hand rear side panel of the tub aligning it with the mud flap and bottom edge of the tub. Use masking tape to hold in place.

83. Mark the centre of the cutting hole on the rear side panel and then remove the template.



84. Using a $\text{\O}70\text{mm}$ hole saw, drill through the rear side panel using the mark from the previous step as the centre point of the hole.



85. Repeat steps 86 to 88 for the left hand rear side panel using the opposite side of the template.

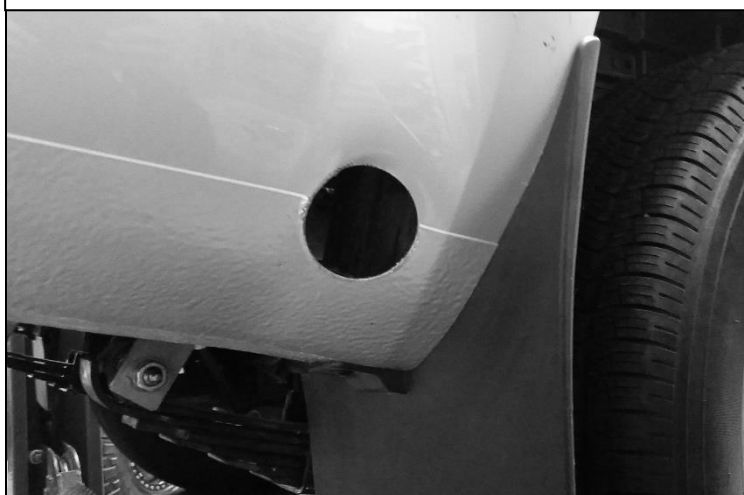

86. De-bur each hole to remove sharp edges.

87. Treat raw edges with a rust preventative paint.

Right Navara wing shown

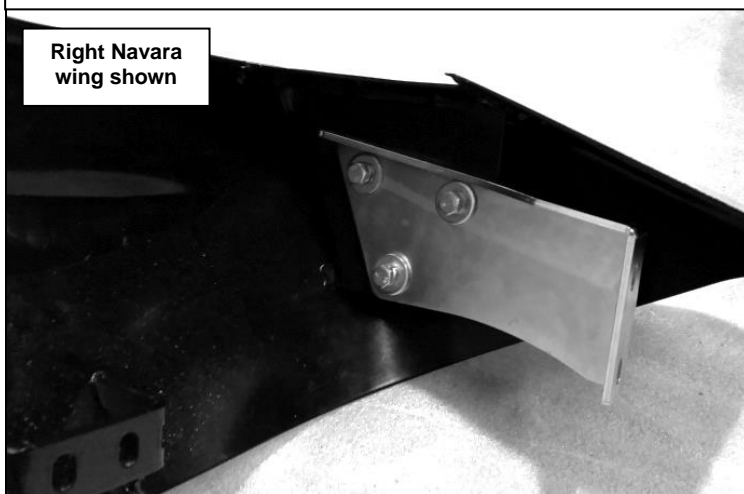

88. Fix a wing mount bracket to each Navara wing using 3 M8x1.25x25 hex head bolts, 3 M8 spring washers, 3 M8 flat washers and a wing triple nut plate. Orientate each bracket as shown. Leave bolts finger tight at this stage.

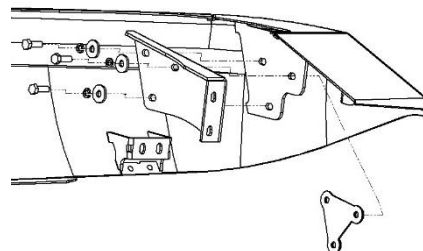

PREPARE RSTB/VEHICLE FOR PANELS

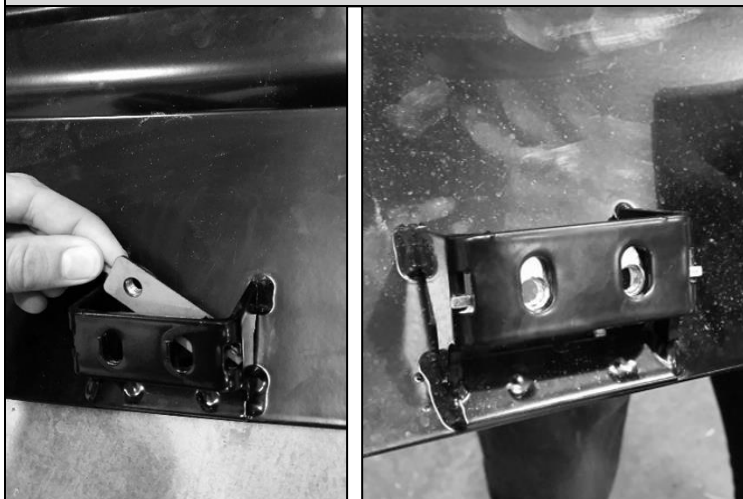

89. Place a wing double nut plate inside the middle bracket of each Navara wing as shown.

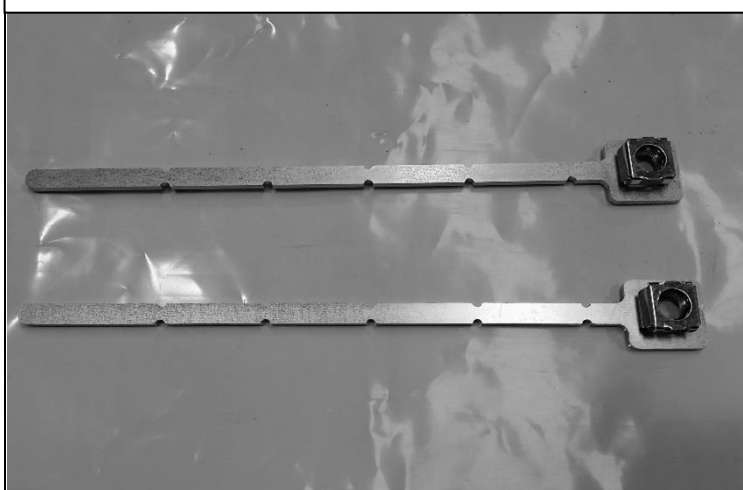

For rear coil sprung vehicles only:

90. Insert 1 M10 caged nut into each cage nut plate as shown.

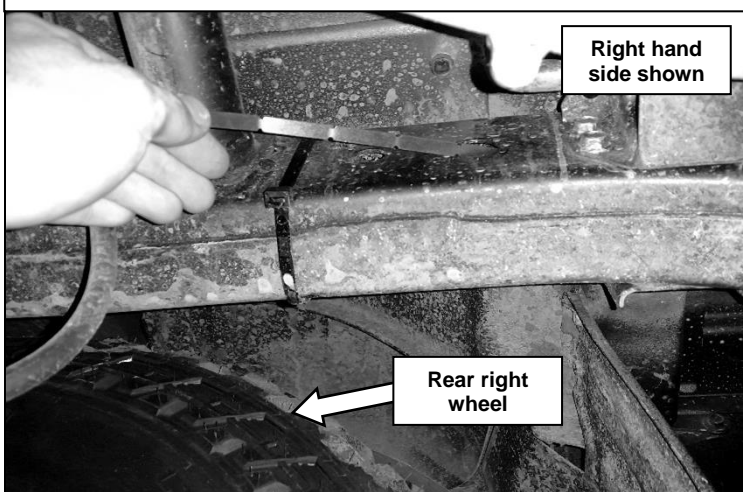

For rear coil sprung vehicles only:

91. Insert a cage nut plate rearwards through a hole on the inner chassis rail face into the chassis rail as shown.
92. Position the caged nut in line with the hole on the outer chassis rail face approximately 150mm rearwards of the inner hole and hold in place.

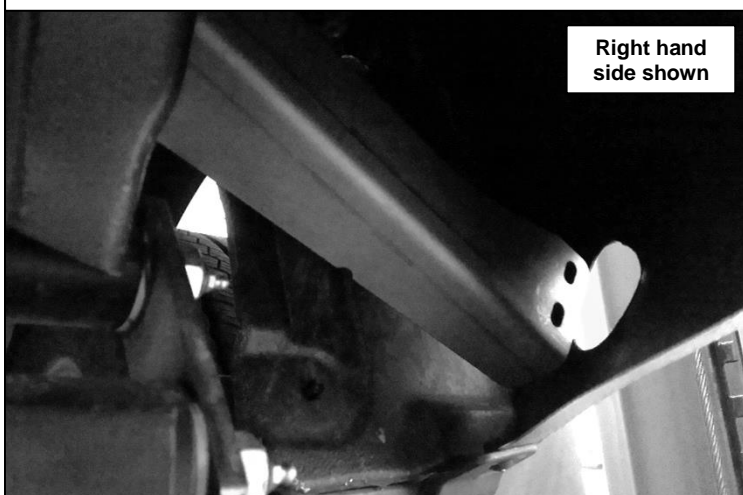

For rear coil sprung vehicles only:

93. Position a wing mount strut under the tub and fix to the cage nut plate in the chassis rail using 1 M10x1.5x35 hex head bolt, 1 M10 spring washer and 1 M10 flat washer. Leave finger tight at this stage.

Note: Strut should be positioned with leading edge towards wheel arch as shown.

94. Repeat steps 93-95 for the opposite side.

PANELS TO RSTB/VEHICLE

Left hand side shown

Balancing weight

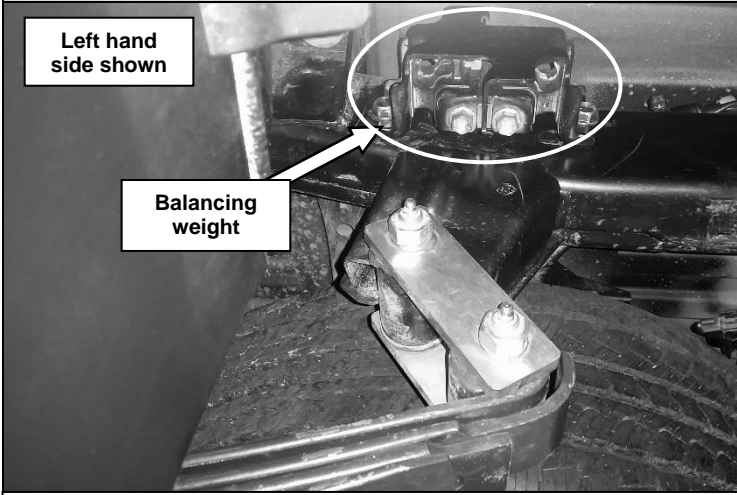

For rear leaf sprung vehicles only:

95. Locate and remove the 2 balancing weights on the outside faces of the chassis rails above the rear leaf spring mount as shown. Retain 2 M10 bolts for the next step.

Right hand side shown

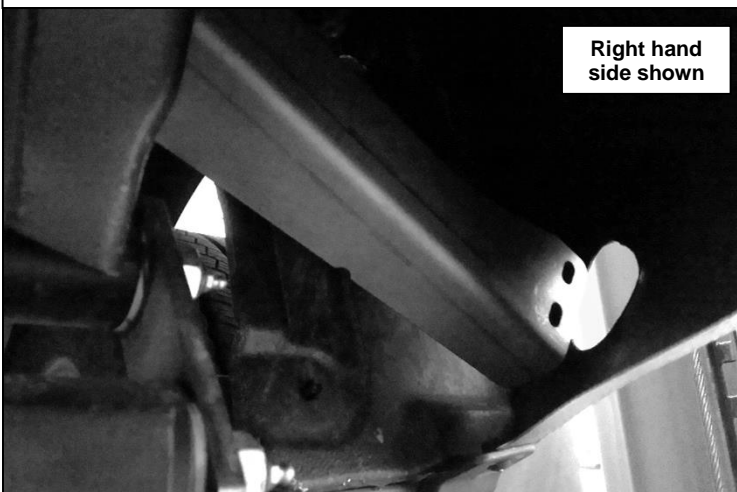

For rear leaf sprung vehicles only:

96. Position a wing mount strut under the tub and fix to the forward M10 weld nut in the chassis rail using an existing M10 bolt from the previous step and 1 M10 spring washer. Leave finger tight at this stage.

Note: *Strut should be positioned with leading edge towards wheel arch as shown.*

97. Repeat step 100 for the opposite side.

1. Push tabs outward and remove sensor

2. Push tabs inward and remove retainer

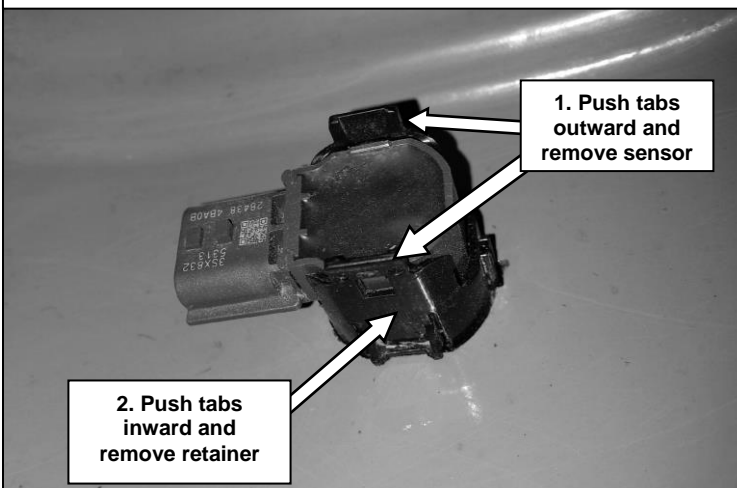

For vehicles fitted with parking sensors:

98. Remove the outer right and outer left parking sensor assemblies from the factory bumper bar. To do this, first unclip the sensor and remove the sensor from the retainer. Remove the retainer from the bumper bar by depressing the tabs on the side as shown.

Note: *Take care to not damage the retainer or sensor when removing from the bumper bar.*

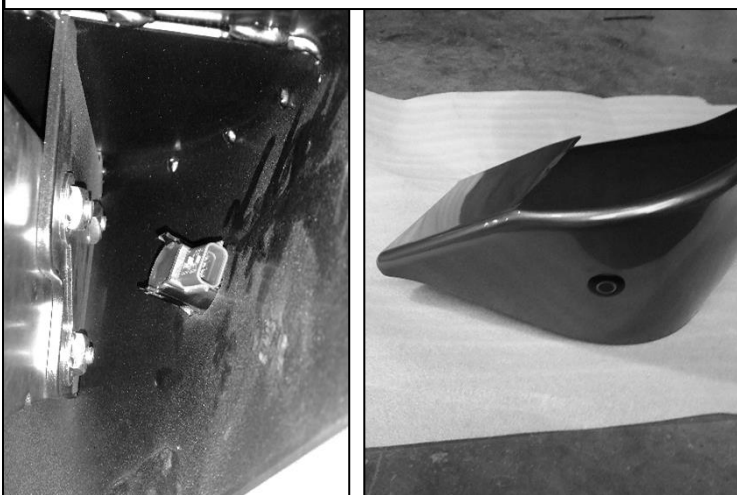

For vehicles fitted with parking sensors:

99. Insert a sensor retainer in each of the Navara wings as shown.
100. Insert a sensor into each retainer with the connector facing the inside of the Navara wing as shown. The sensor will click into place twice.

PANELS TO RSTB/VEHICLE

Right diffuser panel shown



"UP" marking on this face



For vehicles fitted with parking sensors:

101. Remove the inner left and inner right parking sensor assemblies from the factory bumper bar as described in step 102.
102. Insert a sensor retainer in each of the diffuser panels as shown ensuring that the 'UP' marking on the retainer is facing upwards as shown.

Right diffuser panel shown

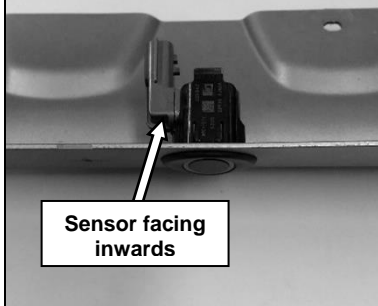

Sensor facing inwards



For vehicles fitted with parking sensors:

103. Insert a sensor into each retainer with the connector facing the inside of the diffuser panel as shown. The sensor will click into place twice.

104. Protect the side and rear vehicle panels using masking tape on each side as shown.

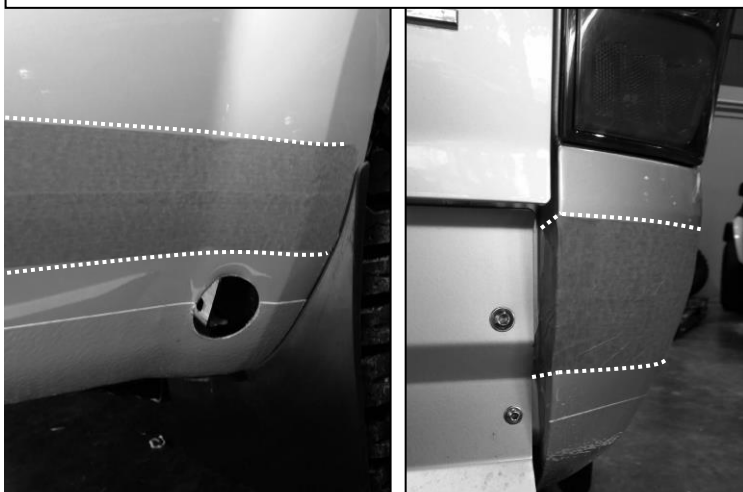

105. Position the Navara wings next to the rear side vehicle panels.

Note: Take care to not damage the vehicle when positioning the Navara wings.

For vehicles fitted with parking sensors:

106. Connect the parking sensors to the parking sensor loom as the Navara wings are positioned against the vehicle.



PANELS TO RSTB/VEHICLE



107. Pass the front bracket of each Navara wing through the $\text{\O}70\text{mm}$ hole in the tub and fasten to the wing mount strut using 2 M8x1.25x25 hex head bolts, 4 M8 flat washers and 2 M8 nyloc nuts. Leave bolts finger tight at this stage.

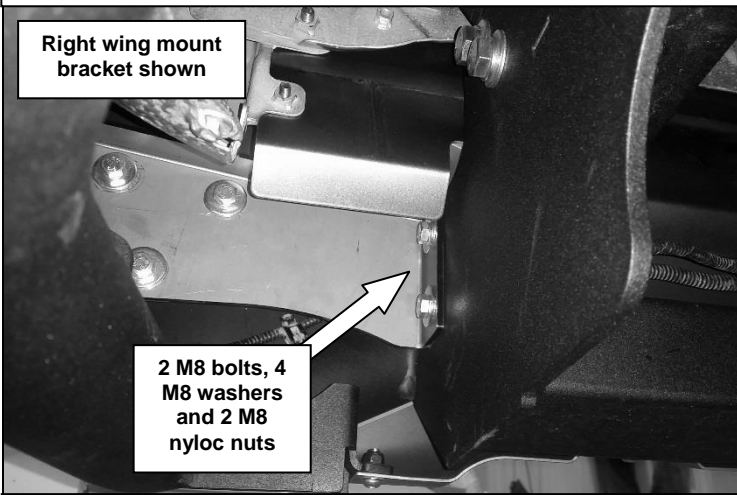
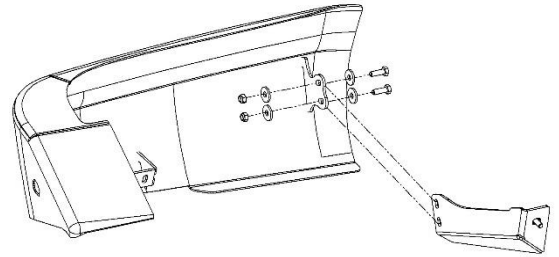

108. Fix the wing mount bracket of each Navara wing to the RSTB using 2 M8x1.25x25 hex head bolts, 4 M8 flat washers and 2 M8 nyloc nuts. Leave bolts finger tight at this stage.

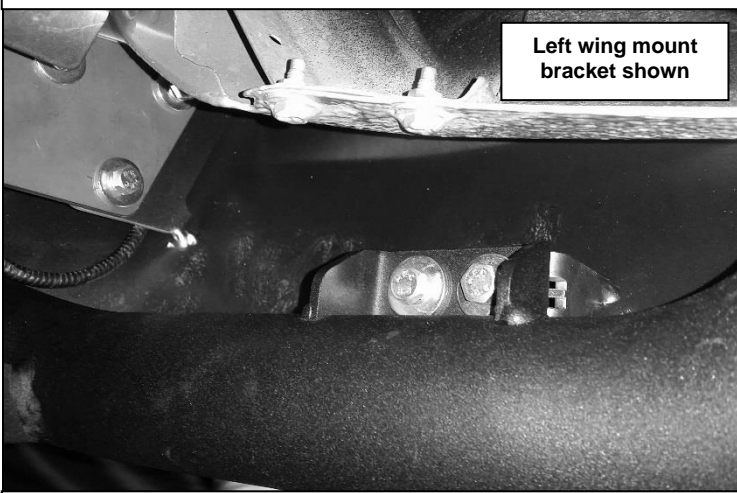

109. Fix the middle bracket of each Navara wing to the RSTB tube using 2 M8x1.25x25 hex head bolts, 2 M8 spring washers, 2 M8 flat washers and the wing double nut plate already fitted. Leave bolts finger tight at this stage.

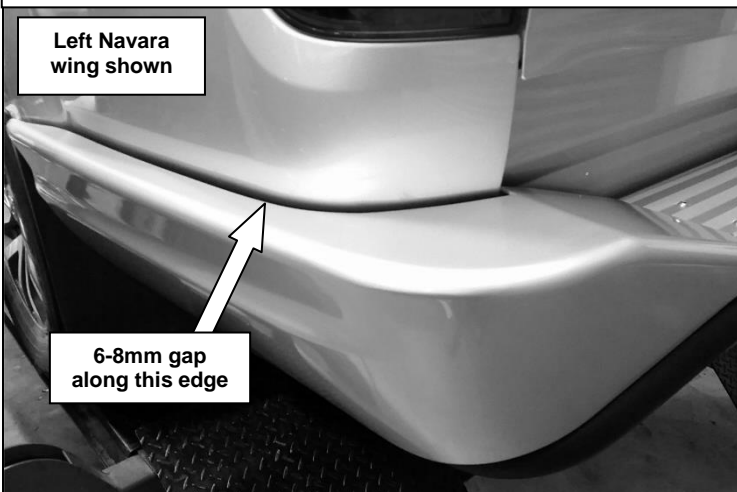

110. Position each Navara wing so there is an even 6-8mm gap to the side vehicle panels.

PANELS TO RSTB/VEHICLE

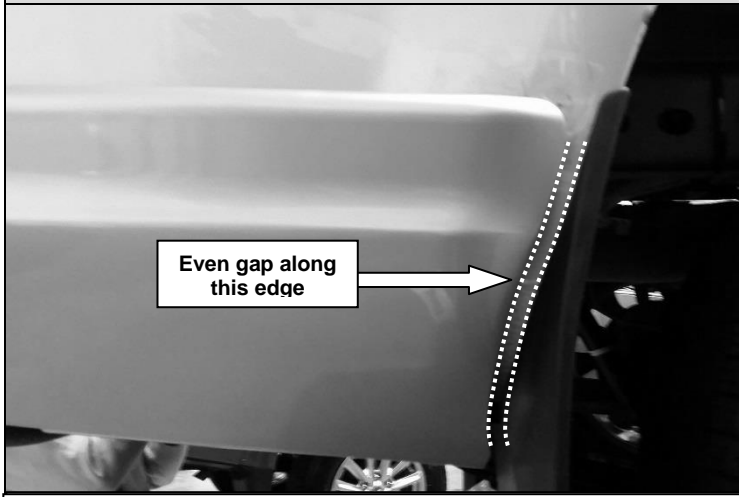

111. Position each Navara wing so the end profile is parallel with the intersection line between the mud flap and vehicle body.

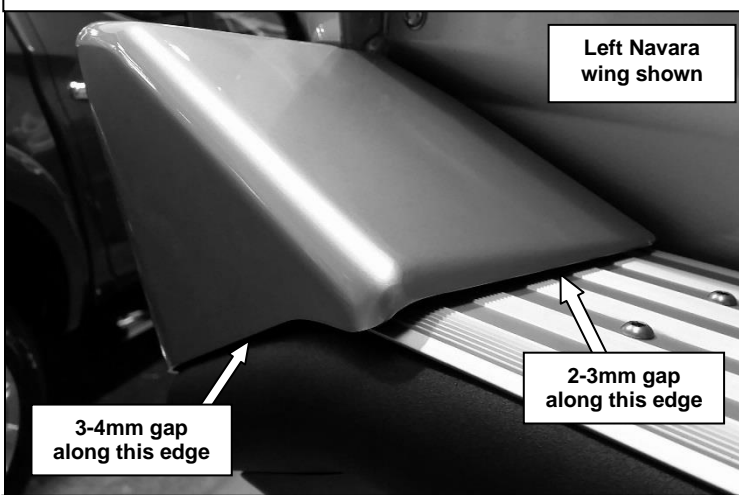

112. Position each Navara wing so they sit evenly on the step plate extrusion and there is an even gap to the tube as shown.



113. Tighten the 9 bolts that retain each Navara wing and the M10 bolts from step 97 or 100 to the specified torque.

 M8 X 1.25 - 22 Nm.

 M10 X 1.5 - 44 Nm.

Note: Check that all clearances are maintained as the fasteners are tightened.

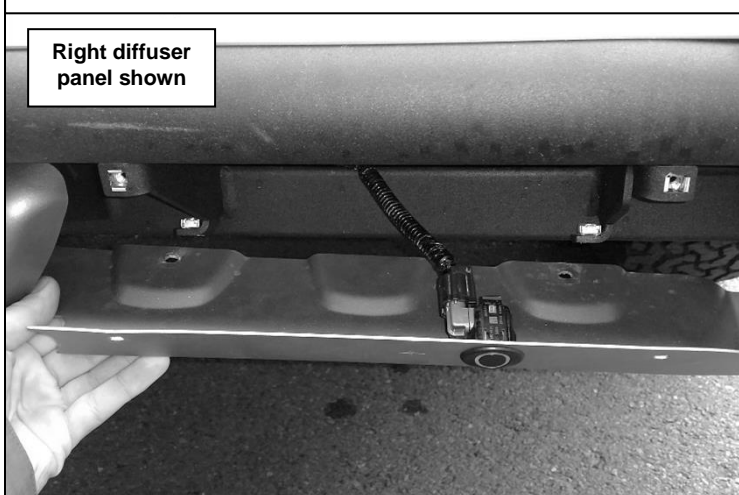

114. Position the diffuser panels on either side of the lift up panel.

For vehicles fitted with parking sensors:

115. Connect the parking sensor to the parking sensor loom as the diffuser panels are positioned next to the lift up panel.

PANELS TO RSTB/VEHICLE

Outside face- M6X20 Hex head bolt and M6x19 black washer.
Inside face - M6 X12 black washer and M6 nyloc nut

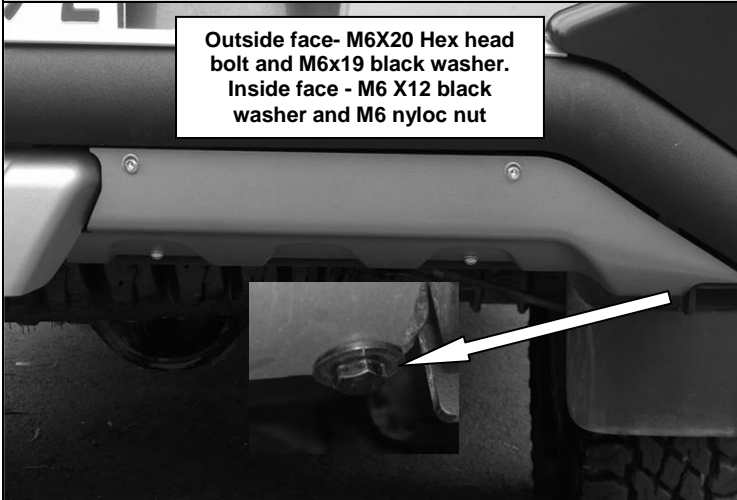

53. Attach the diffuser panels to the RSTB using 8 M6x16 button head screws and M6 stainless flat washers. For the outer most screw on each panel, retain using 2 M6X20 hex head bolts, M6x19 black washer and M6x12 black washer and M6 nyloc nut as shown.

Note M6X19 black washer is to be placed on outside of diffuser panel

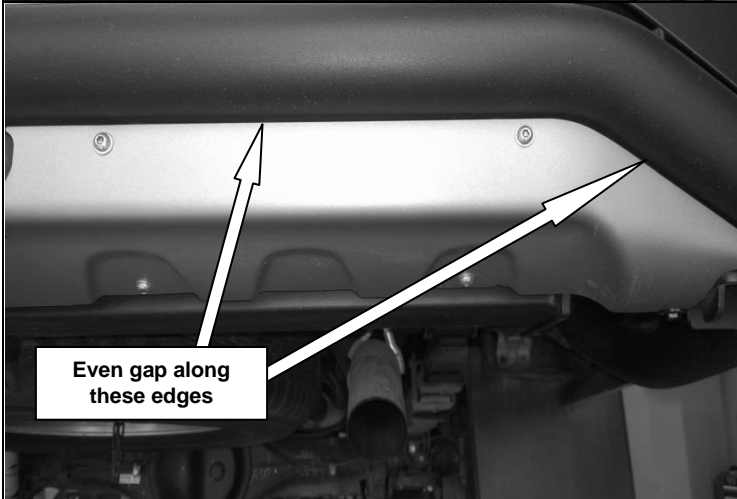

Even gap along these edges

116. Position each diffuser panel so there is an even gap between the panel and the RSTB tube. Tighten fasteners to the specified torque.



M6 X 1 -9 Nm.



117. Test the parking sensors to ensure they are working correctly.

118. Tidy and fasten all wiring using the cable ties provided.

Warning: Make sure all wires are securely fastened away from any hot, sharp or moving surfaces. Do not fasten wiring harness to fuel or brake lines.

119. Test the sensors again as per step 119.



120. Reattach the spare wheel beneath the vehicle tub as shown.

FITTED PRODUCT



FITTED PRODUCT



TRAILER CAMERA PLUG, ANDERSON PLUG AND AIR-LINE FITTING



TRAILER PLUG

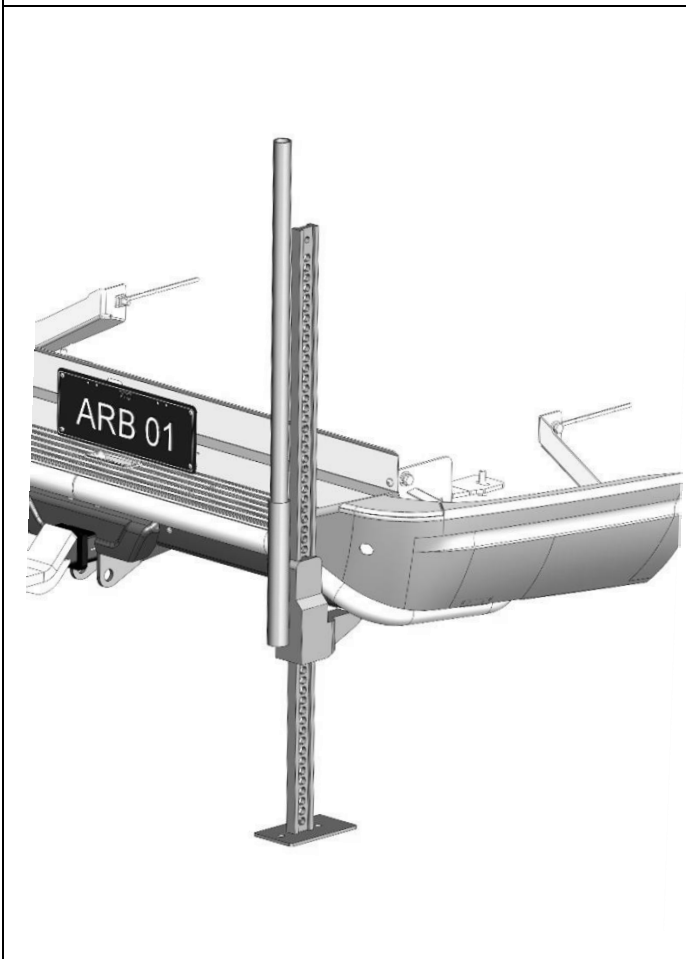

HIGH LIFT JACK LOCATION - CORNER OF RSTB

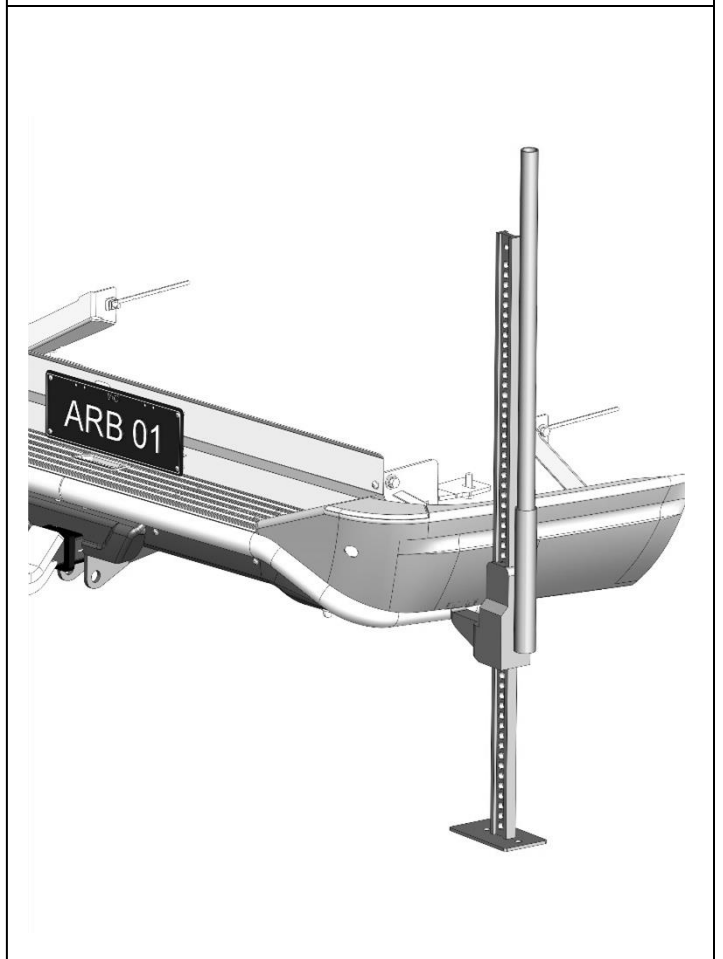

HIGH LIFT JACK LOCATION - SIDE OF WING/ABOVE TUBE

