



FITTING INSTRUCTIONS

Part Number: **3921840**

Product Description: **SUMMIT SAHARA BULL BAR**

Suited to vehicle/s: **Toyota Land cruiser Prado 150 Oct 17 On-GX, GXL, VX and Kakadu**

Optional Kits: **3501000** Winch Install Kit

3163082 ARB FOG LIGHT HOUSING (Non-factory fitted vehicles)

3500590 Fog Light Kit (Non-factory fitted vehicles)

3500530 ARB AUX Fog Light Loom (Non-factory fitted vehicles)

3500680 Fog Lamp Housing Clear Lens Kit

3521050 Front Camera Relocation kit

3521060 Driving Light Loom - Prado

WARNING

REGARDING VEHICLES EQUIPPED WITH SRS AIRBAG:

When installed in accordance with these instructions, the front protection bar does not affect operation of the SRS airbag.

ALSO, NOTE THE FOLLOWING:

- ◆ This product must be installed exactly as per these instructions using only the hardware supplied.
- ◆ In the event of damage to any bull bar component, contact your nearest authorised ARB stockist. Repairs or modifications to the impact absorption system must not be attempted.
- ◆ Do not use this product for any vehicle make or model, other than those specified by ARB.
- ◆ Do not remove labels from this bull bar.
- ◆ This product or its fixing must not be modified in any way.
- ◆ The installation of this product may require the use of specialized tools and/or techniques
- ◆ It is recommended that this product is only installed by trained personnel.
- ◆ These instructions are correct as at the publication date. ARB Corporation Ltd. cannot be held responsible for the impact of any changes subsequently made by the vehicle manufacturer.
- ◆ During installation, it is the duty of the installer to check correct operation/clearances of all components
- ◆ Work safely at all times.
- ◆ Unless otherwise instructed, tighten fasteners to specified torque.

ARB 4x4 ACCESSORIES

Corporate Head Office

42-44 Garden St
Kilsyth, Victoria
AUSTRALIA 3137

Tel: +61 (3) 9761 6622
Fax: +61 (3) 9761 6807

Australian enquiries
North & South American enquiries
Other international enquiries

sales@arb.com.au
sales@arbusa.com
exports@arb.com.au

www.arb.com.au

Last Rev Date: 26/06/2020

Pg 1 of 27

Fitting instructions# 3789804

Copyright © 2005 by ARB Corporation Limited. All rights reserved, this document must not be reproduced without the express authority of ARB Corporation Ltd

GENERAL CARE AND MAINTENANCE

By choosing an ARB Bar, you have bought a product that is one of the most sought after 4WD products in the world. Your bar is a properly engineered, reliable, quality accessory that represents excellent value. To keep your bar in original condition it is important to care and maintain it following these recommendations:



- Prior to exposure to the weather your bar should be treated to a Carnauba based polish on all exposed surfaces. It is recommended that this is performed on a six monthly basis or following exposure to salt, mud, sand or other contaminants.
- As part of any Pre Trip Preparation, or on an annual basis, it is recommended that a thorough visual inspection of the bar is carried out, making sure that all bolts and other components are torqued to the correct specification. Also check that all wiring sheaths, connectors, and fittings are free of damage. Replace any components as necessary. This service can be performed by your local authorized ARB Stockist.

FITTING REQUIREMENTS

REQUIRED TOOLS FOR FITMENT OF PRODUCT:

METRIC SOCKET SET	METRIC RING AND OPEN ENDED SPANNER SET
ELECTRIC DRILL 13 MM CAPACITY	3, 7, 8.5, 10 & 13 mm DRILL BITS
TORQUE WRENCHES 9-96Nm	PHILLIPS AND FLAT BLADE SCREW DRIVER SETS
FELT TIP MARKER PEN	HACKSAW BLADE
FINE FILE OR SAND PAPER	JIG SAW OR MULTI-TOOL WITH BLADE SUITABLE FOR PLASTIC
METRIC TAPE MEASURE	ROLLS OF 25 mm & 50 mm WIDE MASKING TAPE
TOUCH UP PAINT – BLACK FAST DRYING ENAMEL	SCISSORS
SMALL EXT CIR CLIP PLIERS	COLD CHISEL

HAVE AVAILABLE THESE SAFETY ITEMS WHEN FITTING PRODUCT:

Protective eyewear 	Hearing protection 
--	--

NOTE: 'WARNING' notes in the fitting procedure relate to OHS situations, where to avoid a potentially hazardous situation it is suggested that protective safety gear be worn or a safe work procedure be employed. If these notes and warnings are not heeded, injury may result.

FASTENER TORQUE SETTINGS:

SIZE	Torque Nm	Torque lbft
M6	9	7
M8	22	16
M10 / 3/8" UNC	44	32
M12 x 1.75	77	57
M12 x 1.25	96	71

PARTS LISTING			
APPLICATION.	PART NO.	DESCRIPTION	QTY
FIT MOUNT BRACKETS TO CHASSIS	4654407R	BRACKET MOUNT ASSY PRADO 150 RH	1
	4654407L	BRACKET MOUNT ASSY PRADO 150 LH	1
	3757995R	BRACKET REINFORCING MOUNT	1
	3757995L	BRACKET REINFORCING MOUNT	1
	6151306	NUT CAGED M12 1.8-3.2	2
	6151040	BOLT HX HD M10 x 1.25 x 30 GR8.8 TZP480	8
	6151234	BOLT M8 x 1.25 x 25 Gd 8.8 BP	2
	6151094	BOLT M12 x 1.25 x 30 Gd 8.8 ZP	2
	6151255	BOLT M12 x 1.75 x 40 Gd 8.8 ZP	6
	4581040	WASHER FLAT, M10 x 25 x 3 ZP	8
	4581049	WASHER FLAT, 1/2 x 1 1/8 x 3 GOLD ZN	12
	4581307	WASHER FLAT, M8 x 20 x 2 BLK ZN	2
	3194155	PLATE CAGE NUT PRADO 150	2
	6151428	NUT FLANGE M12 X 1.75 ZP	4
FIT MOULDINGS AND LIGHTS	3163197	KIT SURROUND ARB FOGLIGHT SUITS TOYOTA	1
	3500880	GRILLE SPLIT PAN KIT	1
	5100200	BUFF KIT 2PCE FRONT SECTION	1
	6821287	LAMP LED INDICATOR CLEARANCE KIT	1
	180806	CONNECTOR WAGO 222 3 PIN	3
	6821344	CLRNC SIGNAL EXTENSION PRADO18	1
	6821116	GROMMET NYLON SNAP IN TYPE	4
FIT LICENCE PLATE BRACKET	6151213	BOLT M6 x 1.0 x 20 Gd8.8 BZ	3
	4584295	WASHER FLAT M6 X 12 X 1.3 BLK ZN	3
	6151173	NUT FLANGE M6 x 1.0 BZP	3
	6821189	GROMMET RND FC 1500 080 090	2
	3759488	BRACKET LIC PLATE FIXED LARGE RAD	1
	6151384	SCREW ST PHDCOL PH 5.2 X 16 TBZP480	2
MISC	6191025	PINCH WELD 480mm NARROW LONG	2
	6191014	PINCH WELD 330mm NARROW LONG	1
	3789798	CUT TEMPLATE PRADO 150 17ON	1
	180302	CABLE TIE 4.8 X 180 MM BLACK	10
	4584295	WASHER FLAT M6 X 12 X 1.3 BLK ZN	4
	6151173	NUT FLANGE M6 x 1.0 BZP	4
	6523216	PRESS FORM WINCH COVER PANEL	1
	6151213	BOLT M6 x 1.0 x 20 Gd8.8 BZ	4
FIT BAR TO MOUNT	6151428	NUT FLANGE M12 X 1.75 ZP	6
	4581007	WASHER FLAT 1/2 x 1.1/2 x 4 SILVER TZP480	6
	6151360	BOLT M12 x 1.75 x 35 Gd 8.8 ZP	6
	6151357	BOLT SEMS M10 X 30 ZP Gd 8.8	4
	6151321	NUT FLANGE M10 x 1.5 ZP	4

FIT BRACES TO BAR	3195100	BRACE CTR STRAP PRADO 17ON	2
	6151045	BOLT M10x1.5x25 Gd8.8	2
	4581040	WASHER FLAT, M10 x 25 x 3 ZP	2
	6151357	BOLT SEMS M10 X 30 ZP Gd 8.8	4
	6151321	NUT FLANGE M10 x 1.5 ZP	6
FIT WING BRACE	4681651R	BRACE RH WING	1
	4681651L	BRACE LH WING	1
	6151357	BOLT SEMS M10x30	4
	6151321	NUT FLANGED M10	4
TOP FRAME KIT	5100340	TOP FRAME KIT	1
FIT UNDER PANELS TO BAR	6523217	STONE SHIELD PRADO SUMMIT	1
	6523215R	PANEL WING PRADO SUMMIT RHS	1
	6523215L	PANEL WING PRADO SUMMIT LHS	1
	6151315	NUT CAGED M6	8
	6151262	BOLT M8 x 1.25 x 20 Gd 8.8 BZ	7
	4581307	WASHER FLAT, M8 x 20 x 2 BLK ZN	7
	6151301	NUT CAGED M8 3.3-4.7	5
	4581082	WASHER FLAT, M6 x 19 x 1.6 BZ	10
	6151213	BOLT M6 x 1.0 x 20 Gd8.8 BZ	10
6151132	NUT FLANGE M8 x 1.25 ZP	2	
FIT SENSORS TO BAR	3163091	PLUG BLANKING BLK 17.4mm (0-6.4mm PLATE)	4
	6151223	NUT NYLOC M6 X 1.0 BZ	8
	3195099	SENSOR CLAMPING PLATE	4

FITTING PROCEDURE



1. Remove licence plate

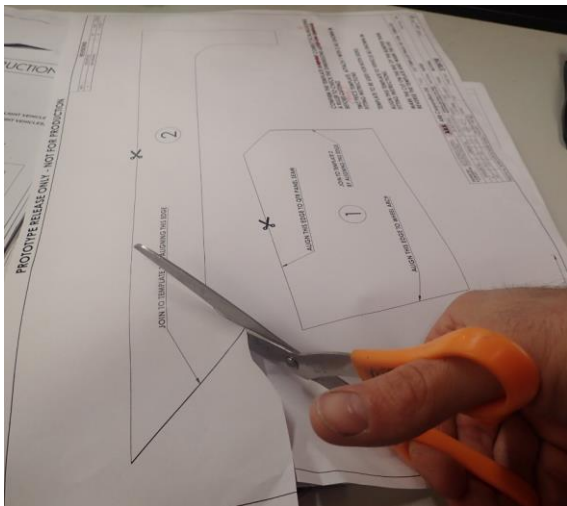

2. Using the scale on template confirm print is to the correct size.
3. Using scissors accurately cut out the bumper cutting template (2 piece) along designated cutting line as shown.

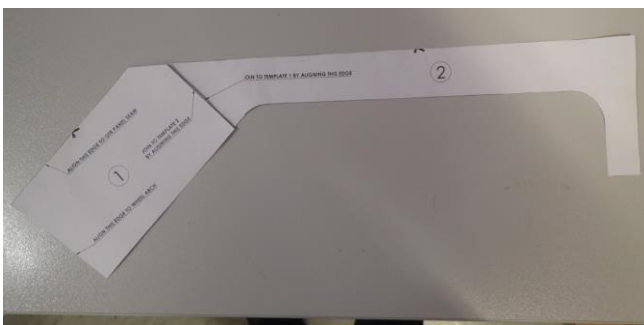

4. Carefully align and join cutting templates along the aligning line as indicated. Tape together front and back.

FITTING PROCEDURE



5. Apply wide masking tape along bumper as shown.

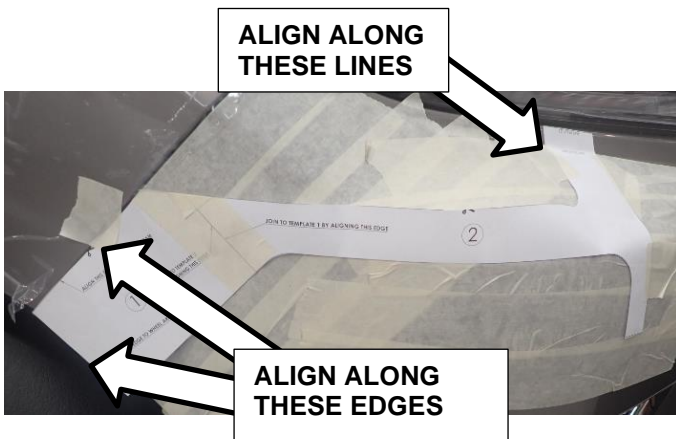

6. Apply cutting template to outer corner of RHS bumper as shown. Align with edge of quarter panel and wheel arch.

Align style lines below headlight with the corresponding lines on the template. (you will need to stretch the template to achieve this.)

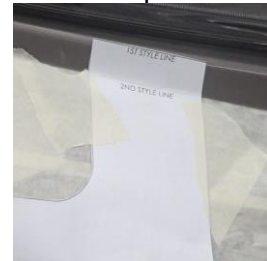

Ensure template is correctly positioned along the edge of the bumper both at the front quarter panel as well as along the wheel arch. Mark along cut edge with a marker.

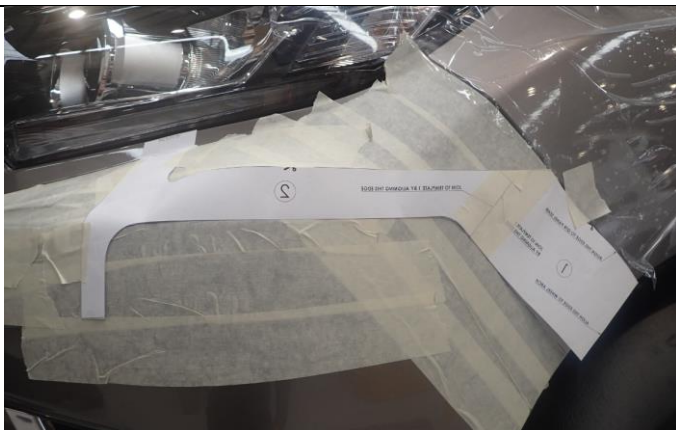

7. Reverse Template and repeat for LHS.



8. Using a straight edge, rule a horizontal line across the front of the factory bumper **30mm above** the top edge of the number plate recess. Finish the ruled line at the vertical styling line at the edge of the grille.

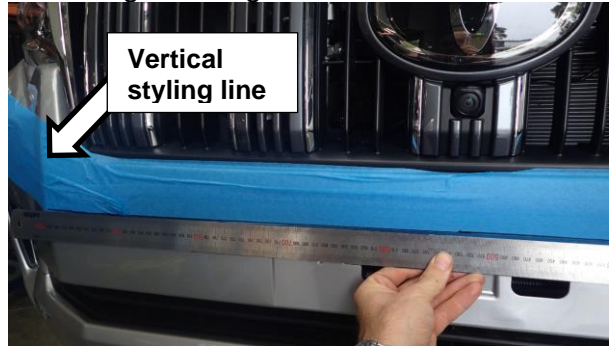

9. Using a straight edge, rule a diagonal line from the end of the cutting template line to the line ruled in previous step.
10. Repeat for LHS.



11. Using a jigsaw or multi-tool carefully cut along the marked edge.



12. If fitted, cut all clips holding head light washer lines to lower section of bumper with side cutters.



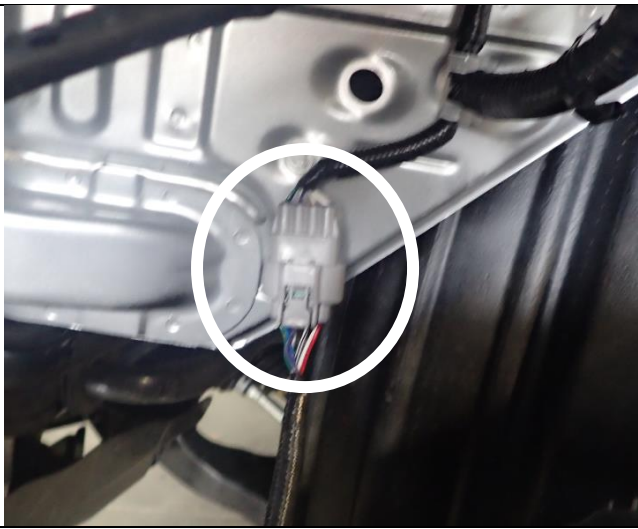

13. If fitted, disconnect the master plug for the front parking sensor loom. Located on passenger side in front of wheel.



14. Remove all bolts and scrivets from below the lower section of the cut bumper.



15. Remove lower screw from inside of each wheel arch which hold lower bumper section to vehicle.



16. Ensure all Head Light Washer lines are free from lower section of cut bumper and the parking sensor loom has been disconnected. Remove lower cut section from vehicle.

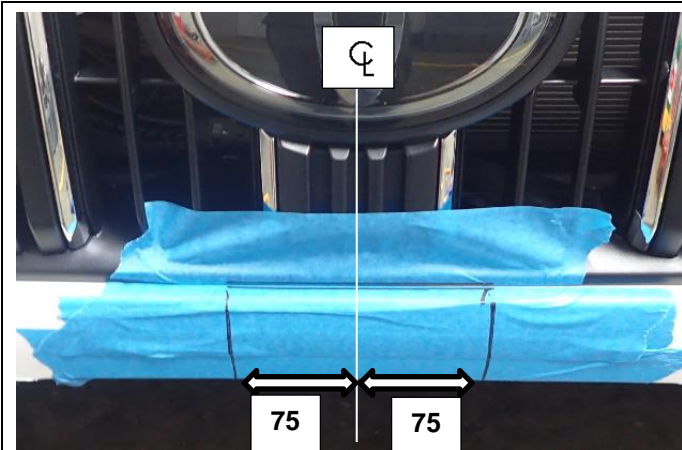

FOR WINCH BARS ONLY:
(IF NOT FITTING A WINCH SKIP TO STEP 20)

17. If fitting a winch, mark and remove with a jigsaw/multitool the centre section of the factory bumper 75mm each side of the centre line of the grille.

****Some control boxes may require removal of additional material****



18. Using a set of vice grips or a shifter, bend the two sheet metal tabs backwards to increase winch control box clearance.



19. Using a set of vice grips or a shifter, bend the two sheet metal tabs backwards to increase winch clutch lever clearance.



20. Fit pinch weld to each outer section of the cut bumper and the winch aperture (if cut).



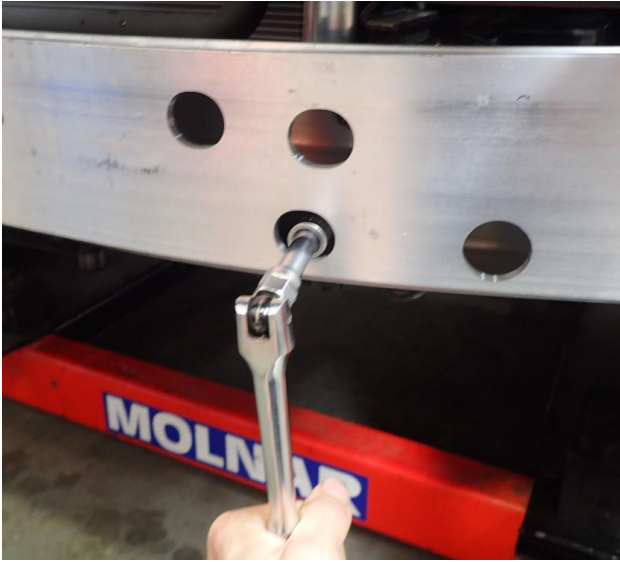

21. Remove crash beam as shown (6 M10 Bolts).
Recycle / discard beam, it will not be reused.



22. Remove crash cans from chassis by undoing
the M10 fine thread bolts. (4 per side)

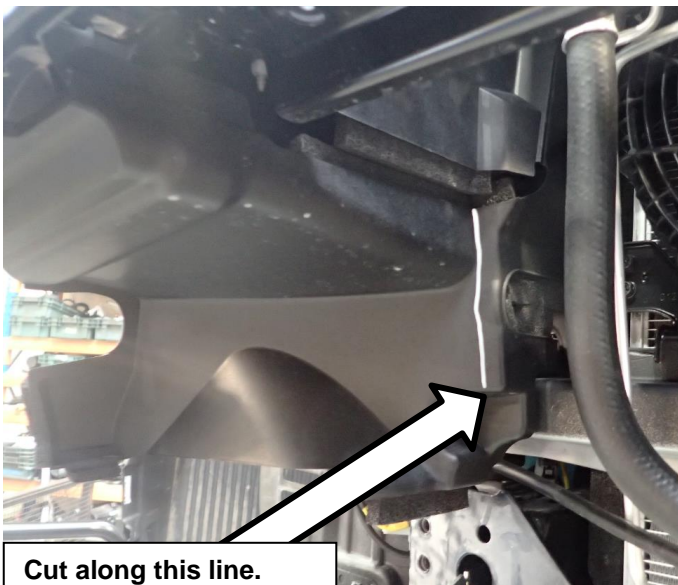

Cut along this line.

23. On the driver's side air deflector, mark a
vertical cutting line as shown. Remove entire
lower section of air deflector to allow fitment
of bull bar mount.

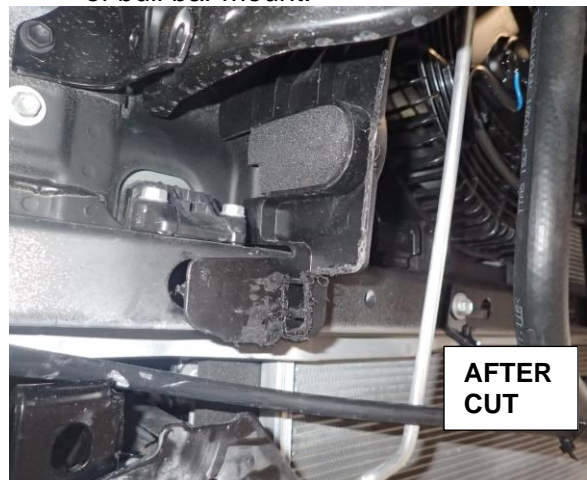

AFTER
CUT

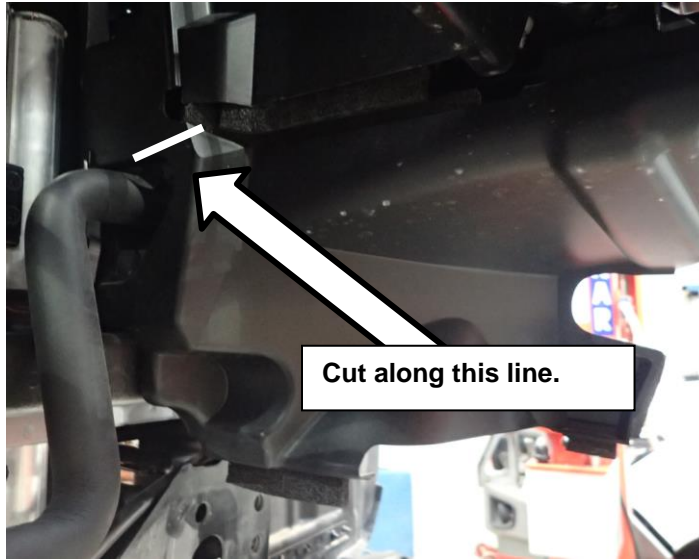

24. On the passenger side air deflector, mark a horizontal cutting line as shown. Remove entire lower section of air deflector to allow fitment of bull bar mount.

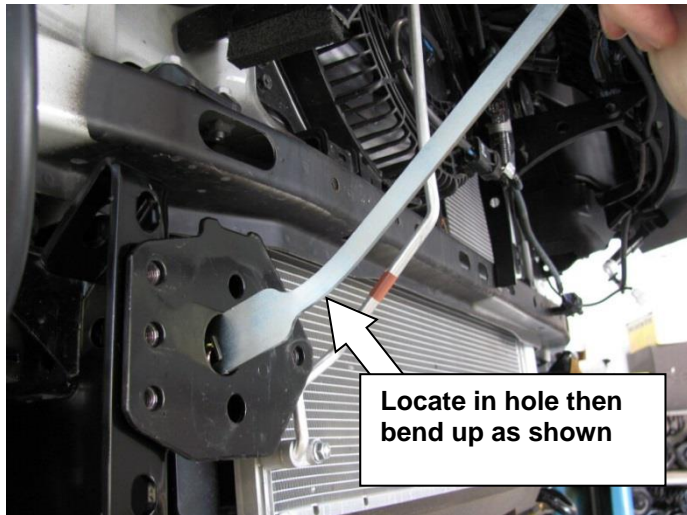
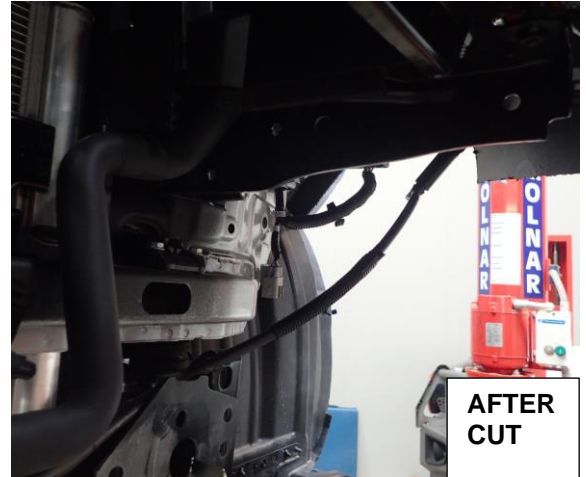

- 25. Fit M12 cage nuts to nut plate extensions
- 26. Bend up the nut plate on the RHS only as shown; this is to clear cross tube in chassis.
- 27. Insert nut plates in chassis holes on both sides with approximately 40 mm still protruding.

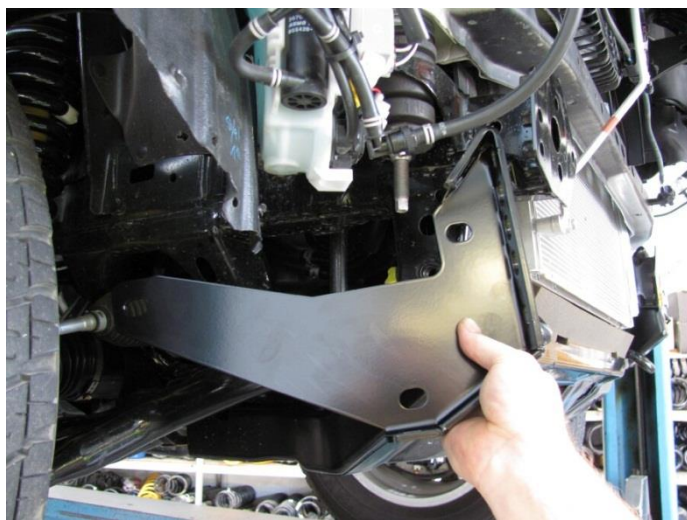

28. Fit handed specific side braces as shown, locating over the captive nuts at the rear of the chassis.

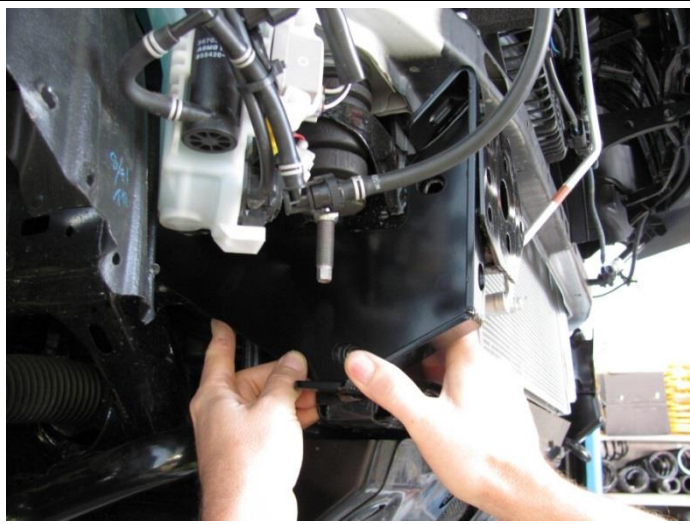

29. When side braces are fitted in position as shown, insert ***fine thread M12 x1.25x30 bolt*** and washer sets into lowest hole position to chassis. There is an existing captive nut in chassis, ***but do not do up tight.***

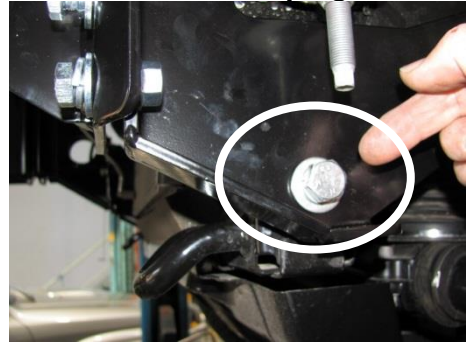

30. Insert M8 x 25 coarse pitch bolt and washer set, ***but do not do up tight. (1 per side)***

31. Insert M12 x 40 coarse pitch bolt and washer set into rearmost hole into cage nut on extension plate, ***but do not do up tight. (1 per side)***

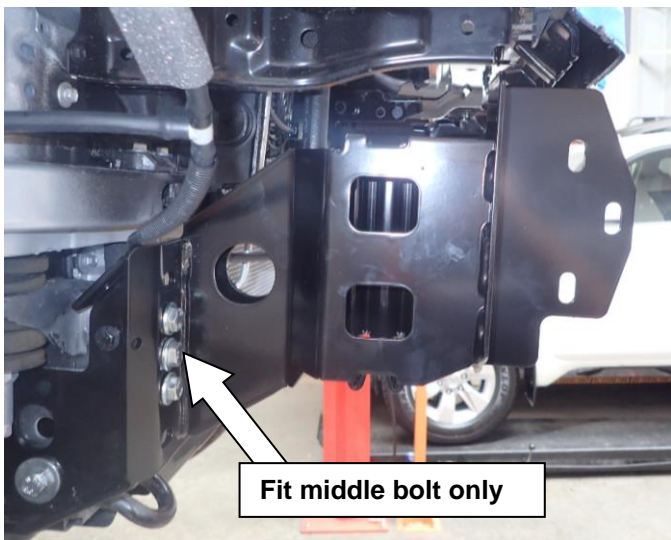
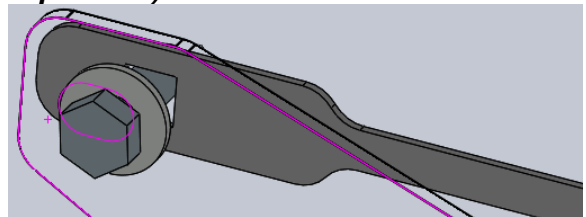

32. Fit impact absorbers to chassis ends using ***fine thread M10 x 1.25 x 30 bolt*** and washer sets supplied, note that the brackets are handed, slide them towards the centre of the vehicle on the adjustment slots ***do not do up tight. (2 per side)***

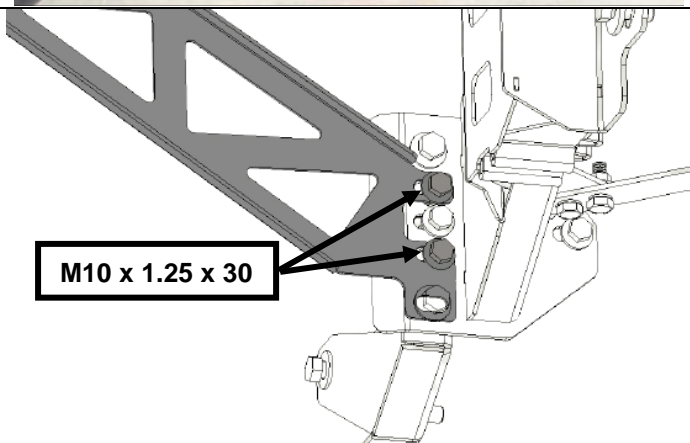

33. Fit wing brace brackets to impact absorbers using ***fine thread M10 x 1.25 x 30 bolt*** and washer sets supplied. ***Do not do up tight. (2 per side)***

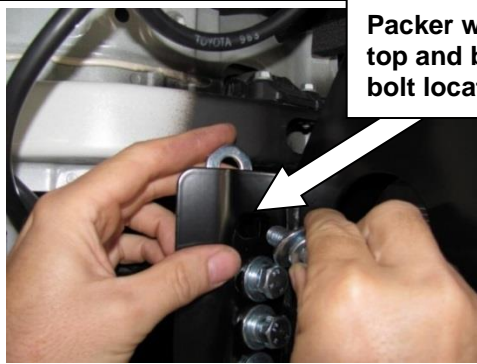

**Packer washers
top and bottom
bolt locations**

34. Fit M12 bolt, washer and flange nut sets to top and bottom positions as shown. (2 per side) Insert M12 flat packing washer between the rear face of the impact absorber flange and the front face of the side brace as shown, **but do not do up tight. (2 per side)**
35. Once all bolts are in place nip up the bolts in the side brace.

Note: If fitting a winch proceed using fitting instructions 3789337 supplied with 3500720 winch install kit. Once the winch is fitted please continue to step 39. If no winch is being fitted continue from step 36.

****ENSURE WINCH CONTROL BOXES ARE ADJUSTED ALL THE WAY FORWARD****

36. Slide the winch cover panel from the bottom up until it is level with the top face of the bar.

37. Fit the winch cover panel to the bar using 4 x M6 x 20 hex bolts, flat washers and flange nuts.

Warning: Be careful not to scratch the finish of the winch cover panel.

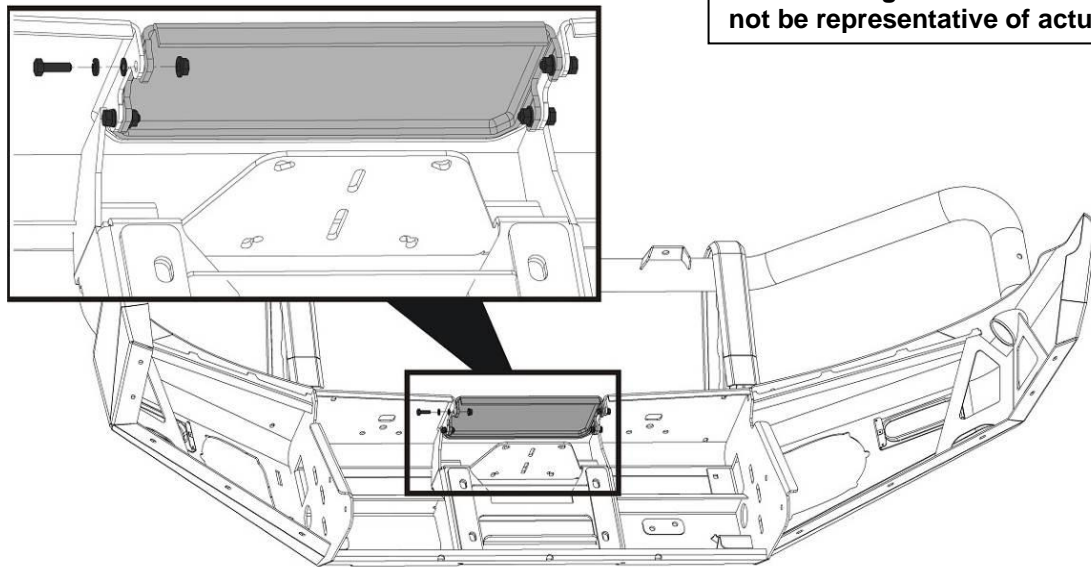

Generic image. Bull Bar shown may not be representative of actual product.

38. Fit the number plate bracket to the top face of the lower-centre pan on the bar using 3 x M6 x 20 hex bolts, flat washers and flange nuts.

Note: If you are fitting a winch, fit the folding number plate bracket supplied in winch install kit "3500720 WINCH INSTALL KIT" – See fitting instructions 3789337

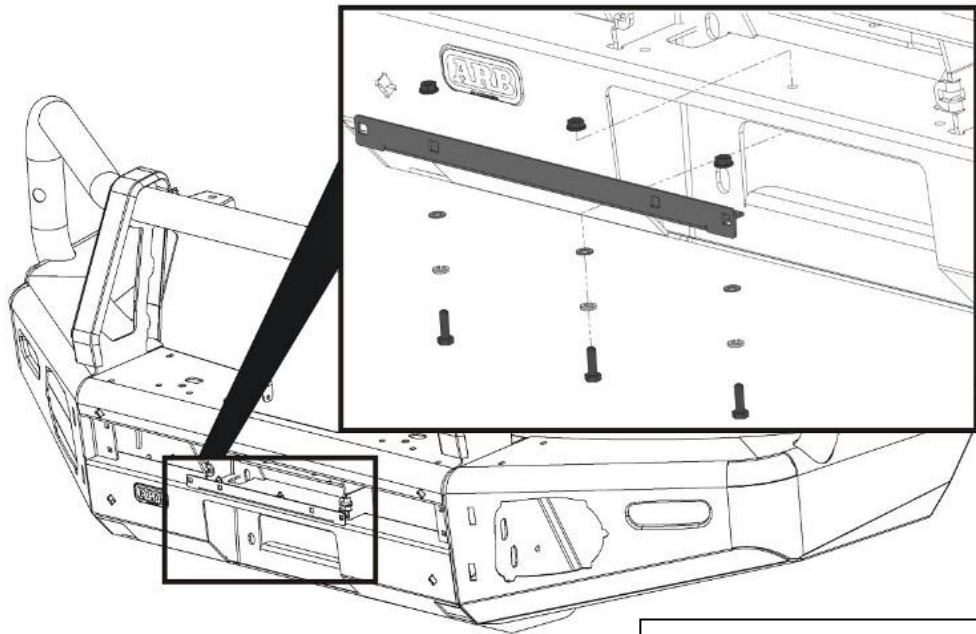

Generic image. Bull Bar shown may not be representative of actual product.

39. Layout the contents of each of the following kits ensuring the contents are kept separate from each other.

Note: The following steps show the fitment of the plastic moulded parts. The mouldings are supplied in kits along with all fasteners required for fitment. It is important that the fasteners supplied with each kit are only used for the mouldings from the same kit.

The kits included in this bar kit are as follows:

Kit No.	Description
5100200	BUFF KIT 2PCE FRONT SECTION
5100260	BUFF KIT 2PCE REAR UPRIGHT BAR
3500880	SPLIT PAN MESH KIT
3163156	FOG SURROUND KIT

40. Mark the grille panel to be cut at the 880mm marks at each end on the back face.

Note: When marked, double check the measurement with a measuring tool.

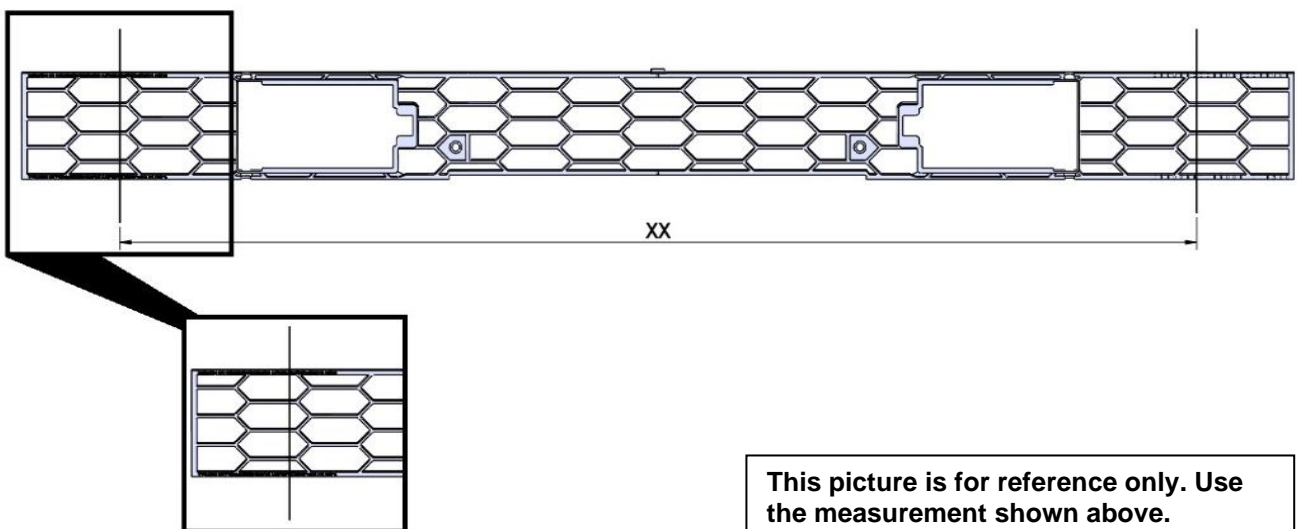

This picture is for reference only. Use the measurement shown above.

41. Use a hacksaw or similar cutting tool to carefully cut the grille panel at the positions marked in the step above.
42. Discard the off cuts and clean up the cut edges using a file or sandpaper.

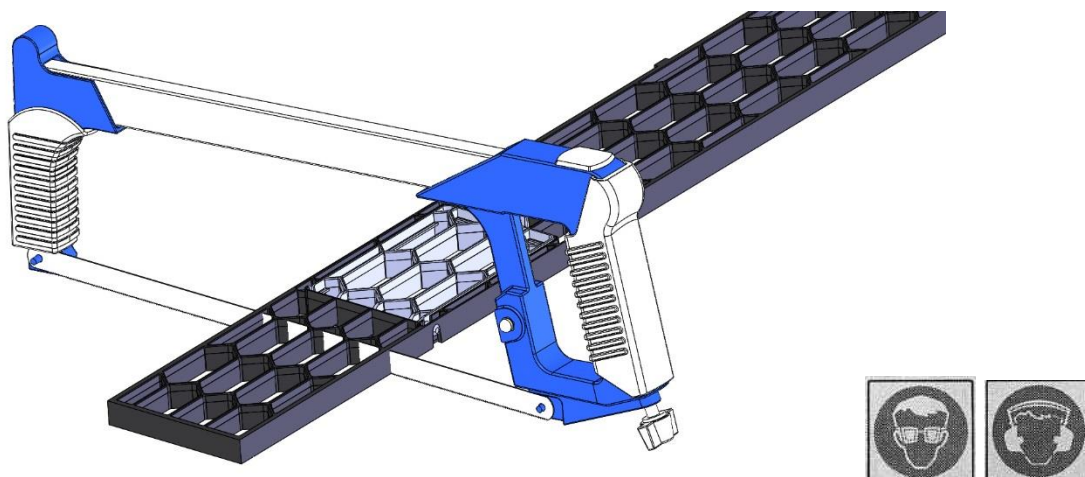

43. Insert the 6 x plastic grommets into the 6 square holes in the front face of the bar.
44. Insert the grille into the bar so that the hatches open outward (facing the front of the bar).
45. Attach the grille to the centre of the bar using the short screws into the grommets fitted above.
46. Attach the ends of the grille to the bar using the longer screws, through the clamp plates into the remaining grommets.

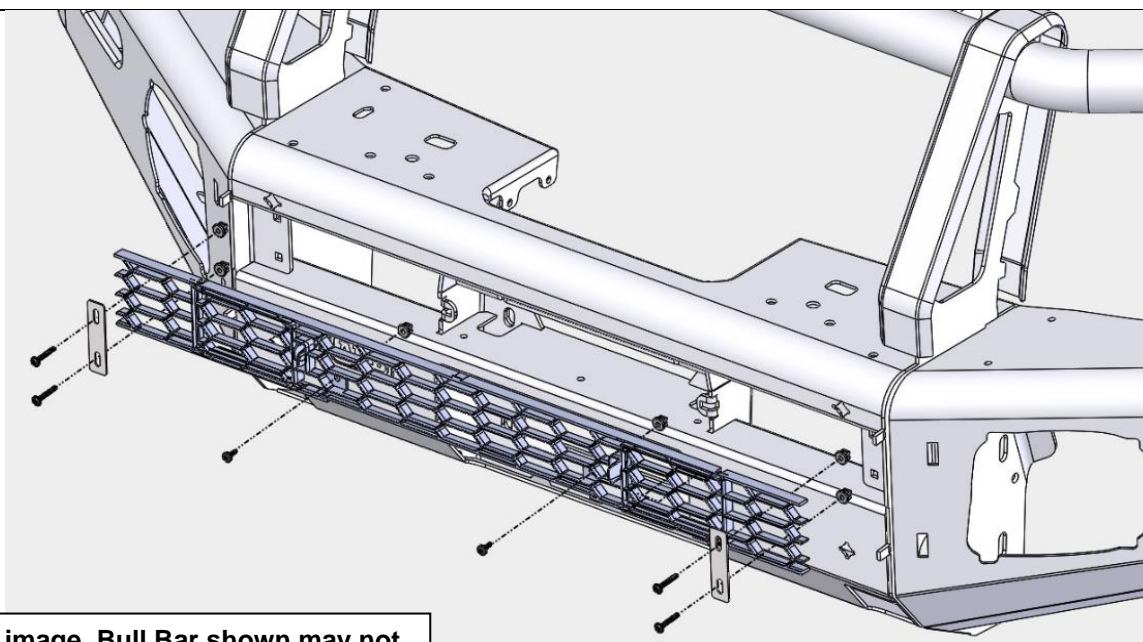

Generic image. Bull Bar shown may not be representative of actual product.

46. Place each of the Top Buffer sections onto the bar as shown. Ensure that the buffers are

keyed together correctly. Fit 5 x screws and washers. Do not tighten screws. Leave enough play in buffers for adjustment later.

Fit washers under screw heads.

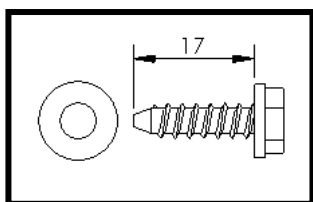
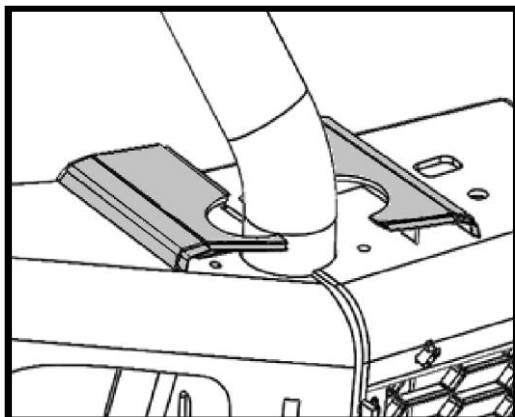

Generic image. Bull Bar shown may not be representative of actual product.

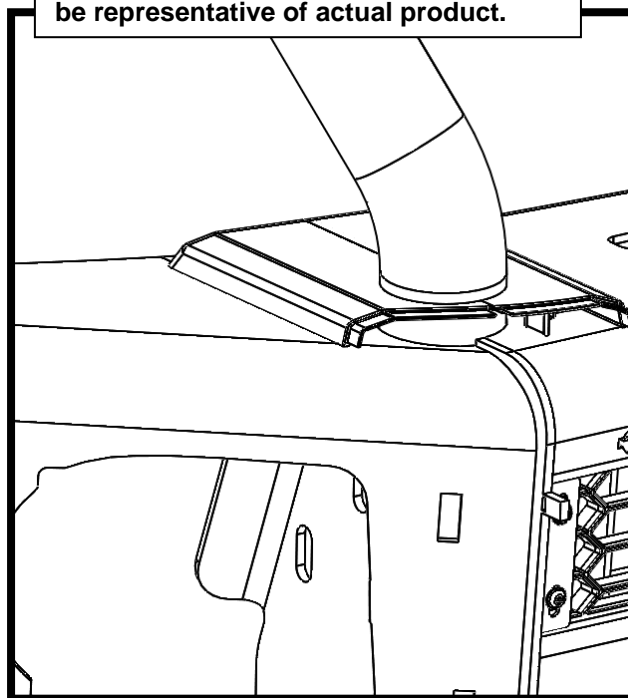

47. Attach the buffers to the front face of the bar using the angled cup washers, flat washers and screws.

Insert clips through buffer tabs as shown.

Ensure the key on the top sections engage in the groove on the front buffer.

The widest point of the cup washers goes to the top of the bar.

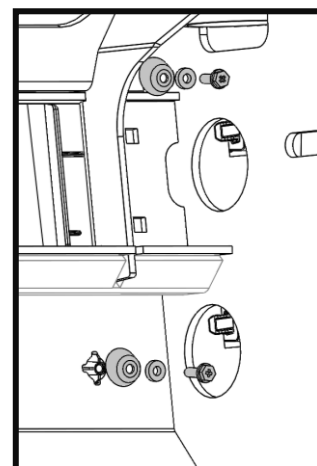
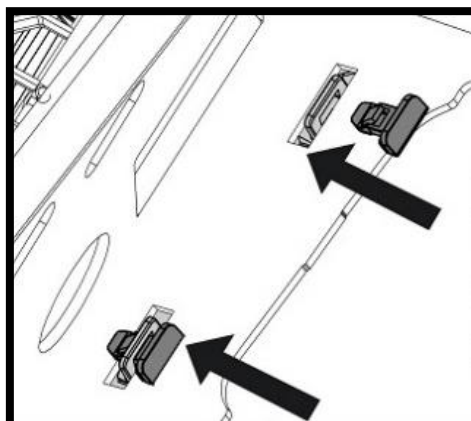
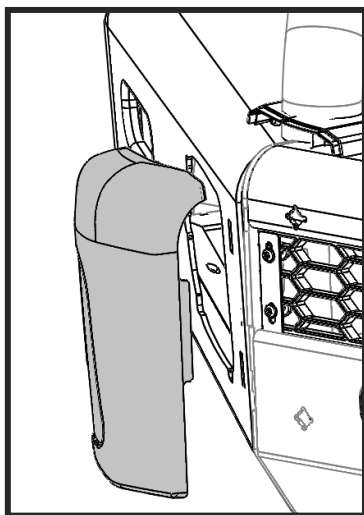

Fit washers under screw heads.

Generic image. Bull Bar shown may not be representative of actual product.

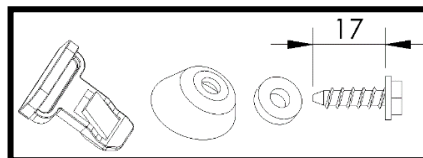



FOR KAKADU & VX ONLY:

47. Install camera relocation kit 3521050 now as per fitting instruction in kit.

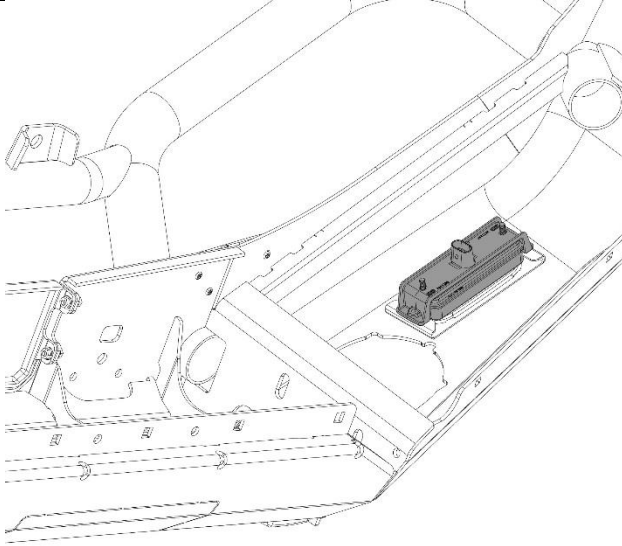

48. Fit the small plastic grommets to the bar and attach the combination LED lamps to the bar using the screws provided with the lamp kit.



For vehicles without factory fog lamps:

49. ARB loom 3500530, housing kit 3163082 can be fitted to bullbar so that ARB fog lights 3500590 can be fitted.

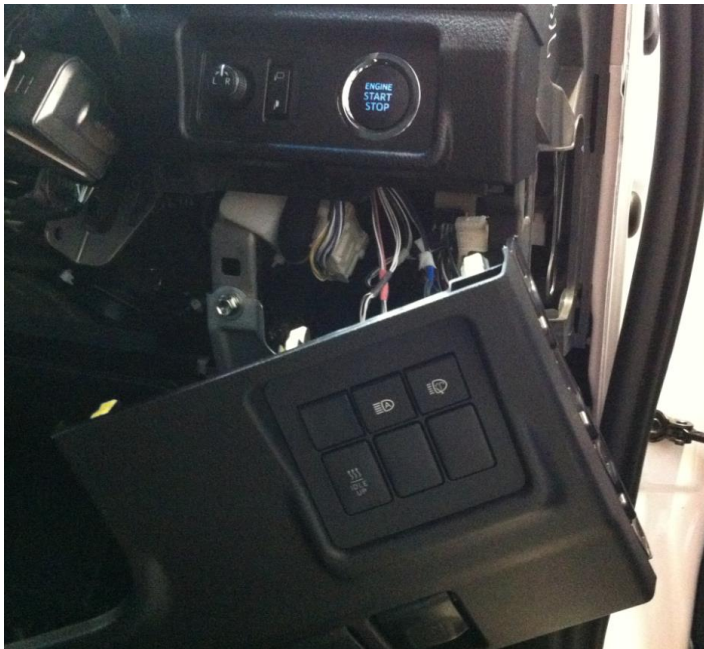

50. Due to CANBUS wiring system on vehicles fitted with LED headlights, there is no usable power supply/signal for the bullbar clearance lights on the connector at the head lamps.

Using the supplied loom 6821344, power supply for the clearance lights needs to be taken from the 'idle up' switch in the cabin.

- a) From the engine bay feed the supplied loom (uninsulated end) through the fire wall using the existing grommet below the brake fluid reservoir.
- b) On driver's side, unclip and remove the side panel from dashboard.



- c) Remove screws from plastic panel underneath steering column.
- d) Unplug 'idle-up' loom from switch for easy access.

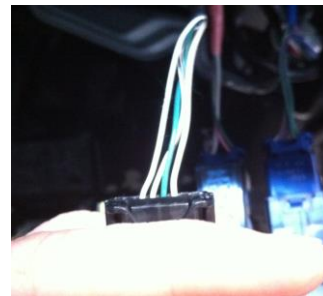

- e) Using the supplied WAGO connector, connect supplied loom 6821344 to the green wire on idle-up switch.
- f) Reconnect idle up switch and reassemble panels removed in previous steps.



51. Power supply for the indicator circuits can be taken from the large connector under the head lamps. Rotate the grey lock downwards and disconnect the connector for ease of access.

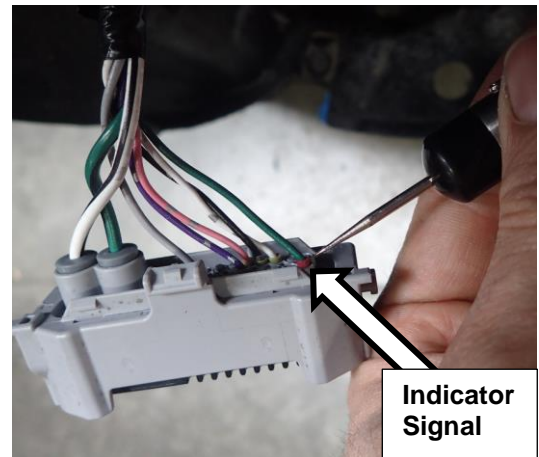

LED INDICATOR/CLEARANCE LOOM	
Cable Colour	Function
RED	CLEARANCE (+)
GREEN	INDICATOR (+)
BLACK	GROUND (-)
VEHICLE LOOM RHS	
Colour	Function
RED	CLEARANCE (+)
GREEN	INDICATOR (+)
VEHICLE LOOM LHS	
Colour	Function
RED	CLEARANCE (+)
PURPLE	INDICATOR (+)

52. Using supplied scotch locks, connect the LED Indicator/clearance light looms as per table.

As shown above, RHS indicator signal is the small green wire.

LHS indicator is the small purple wire.

Using the supplied WAGO connectors, connect to loom 6821344 for clearance circuit.

Ground can be achieved by earthing black wire of supplied indicator loom to body of vehicle.

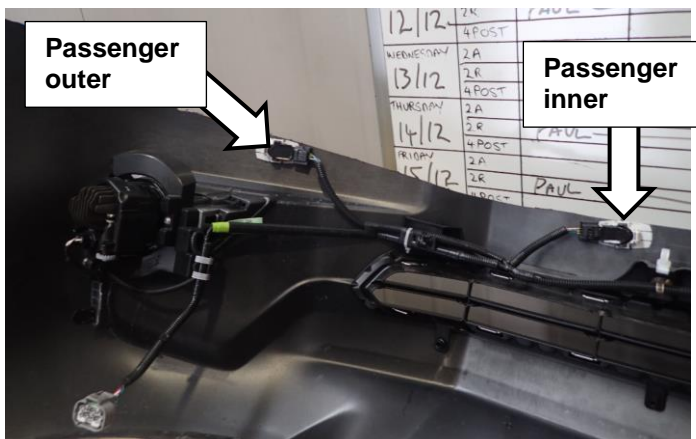

**FOR VX & KAKADU ONLY:
(IF GX OR GXL SKIP TO STEP 59)**

53. Before removing parking sensor loom from the offcut bumper section, label each plug as follows:

- 1 driver side inner
- 2 driver side outer
- 3 passenger side inner
- 4 passenger side outer

54. Route the sensor loom behind the grille in bull bar uprights and secure with cable ties. Ensure correct orientation of the sensor loom according to system above.



55. Gently remove sensors and housing from bumper by prying off with a flat screw driver.
56. Unclip sensor and black retainer from white housing. Discard white housing.

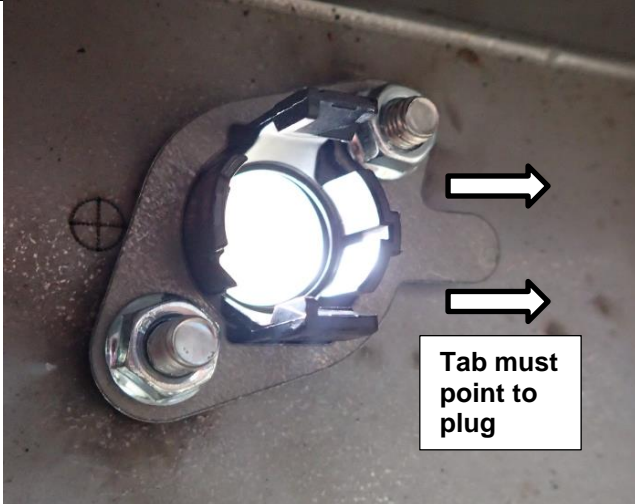
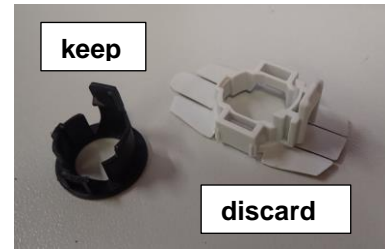

57. Clamp black retainer to bull bar with steel clamping plate by fastening Nyloc nuts onto bull bar studs.

****TAB MUST POINT TOWARDS PLUG****

58. Press sensors into black housings and connect loom to sensors.

CHECK SENSOR IS CONCENTRIC IN HOLE, IF NOT ADJUST.

Note: When fitting parking sensors to the bar it is important that they are installed in the correct orientation. The arrows below show the direction the plug end of the sensors should face.

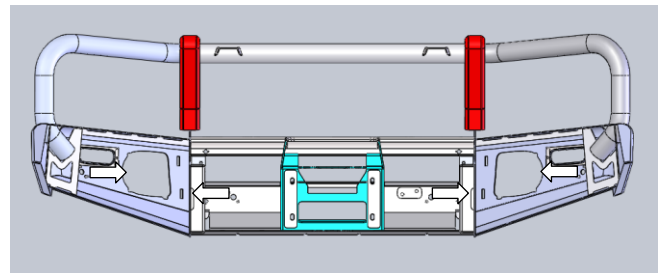

Note: Electrical tape on the loom may need to be carefully unwrapped in order to lengthen loom. Secure with cable ties.



59. If not fitting parking sensors, press dome plugs into sensor holes in bar.



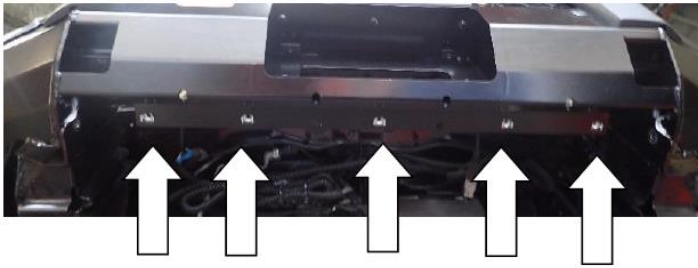

60. Fit M8 cage nuts to the lower pan of the bar as shown.



61. Ensure all other aftermarket accessories such as driving lights/winch/UHF aerial have been fitted to the bull bar.

NOTE: Winch Roller Fairlead must be drilled to 25mm offset if not already done so.

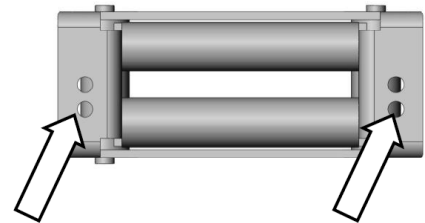

62. With the aid of a lift table or one or more assistants carefully and safely lift then position and loosely bolt the bull bar to the mounts using 6 x M12 bolts, large flat washers and M12 flange nuts. Centralise the bar to the front of the vehicle.

NOTE: DO NOT DO UP TIGHT



63. Attach the bar to the mount bracket using 6 x M12 X 40 bolts, 6 large diameter M12 flat washers & 6 x M12 flange nuts. Leave loose at this stage.

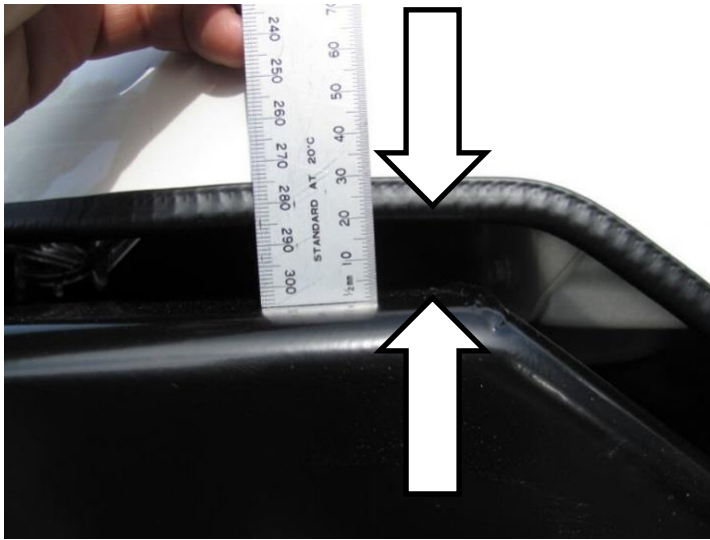

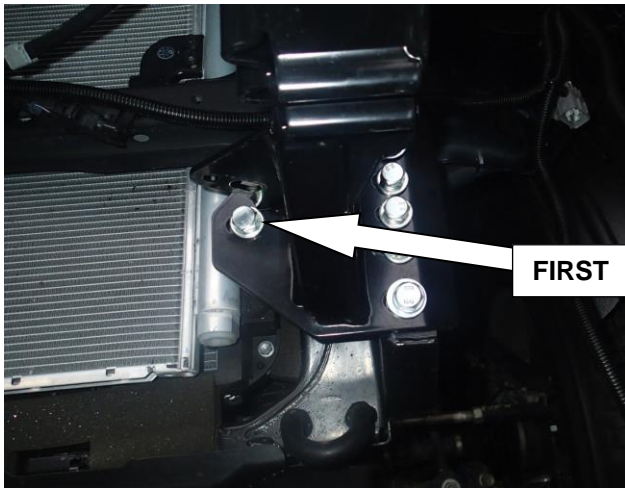

64. Ensure the bar is sitting on the vehicle level and the gap between the bumper bar cut and the bull bar wing is even.

**18-20 mm GAP
REQUIRED**



65. If the bull bar is not centred on the vehicle, back off the mount bracket bolts to chassis, tap the mount brackets sideways with a soft hammer until the bar is central. Retention bolts to specified torque.

 M12 X1.75 - 96 Nm.

 M12 X1.75 - 77 Nm.

 M10 - 44 Nm.

Tighten the inner bolt shown on **both** sides first. Only then move onto outside bolts. Failure to do so will skew the bar to one side of the vehicle.

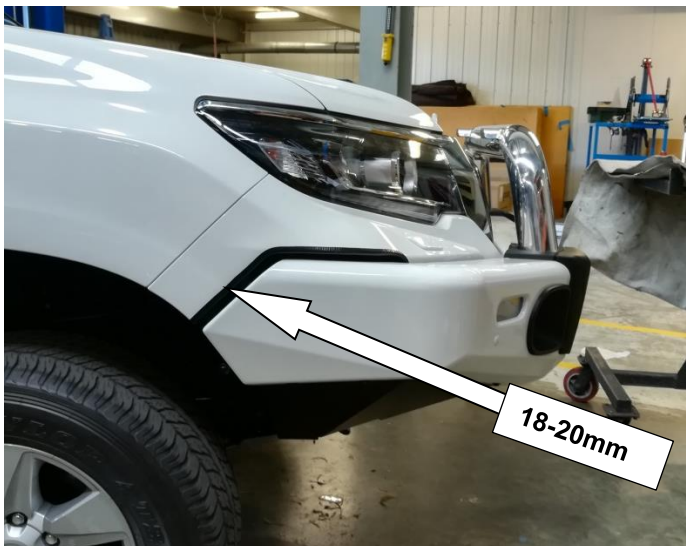

66. Once happy with the position of the bull bar and the clearance gap is 18-20 mm, tighten all the mount bolts to specified torque.

 M12 - 77 Nm.

 M10 - 44 Nm.



67. Using an electric drill and a Ø10.0 mm drill bit, drill two pinning bolt holes through the bull bar upright each side using the holes in the mount bracket flanges as a guide.

Warning: Drilling operations can result in flying metal debris, safety glasses should be



68. Fit the pinning bolts to the bull bar in the drilled positions using 4 x M10 SEMS bolt and washer sets and M10 flange nuts.

 M10 - 44 Nm.



69. Attach lower brace straps, ensure the top face of the brace strap mates with the underside of the bull bar brace mount, and the underside of the brace strap mates with the top face of the impact absorber gusset as shown in the figure.

70. Fix to impact absorber tabs with 1 X M10 SEMS bolts and flange nuts.

71. Fix to bull bar with 1 x M10 X 25 bolts, and 1xM10 flat washer.

Tighten the M10 bolts retaining the bull bar brace mount.

 M10 - 44 Nm.



72. Using a Ø10 mm drill bit, drill and pin the straps at the adjustment end using the pilot hole as a guide, as shown (note strap fits above the gusset as shown).

73. Fit and torque the M10 pinning bolts and flange nut sets to specifications

 M10 - 44 Nm.



Warning: Drilling operations can result in flying metal debris, safety glasses should be worn.

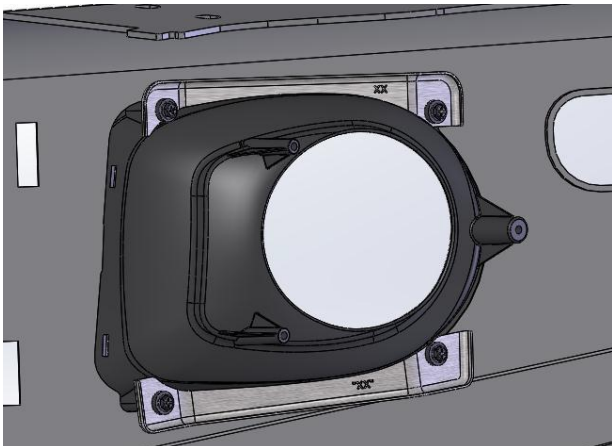

74. Install Fog light surrounds (3163197) as per instruction no. 3789800 supplied with surround kit into aperture of bull bar.

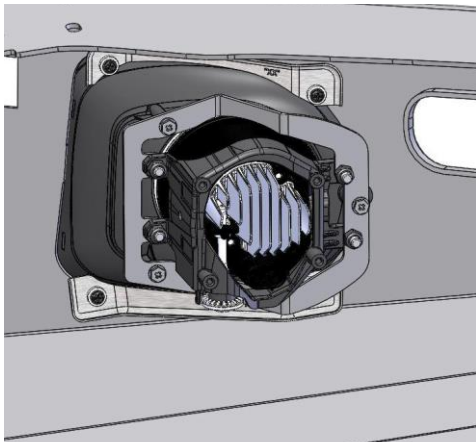

47. Assemble fog lights into surrounds as per instruction no. 3789800 supplied with surround kit 3163197.

Notes:

Optional clear covers (3500680) can now be fitted to the housings using fitting instruction no. 3789191.

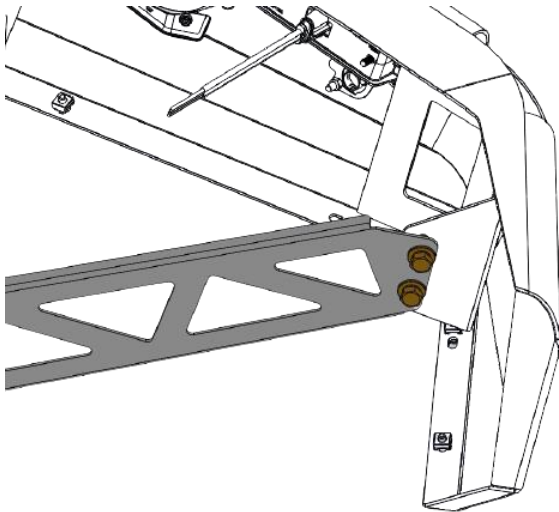

48. Attach wing brace bracket to Bullbar using M10 SEMS bolts and flange nuts in the locations shown to the left.



M10 - 44 Nm.



75. Fit 4 X M6 cage nuts into each of the under wing panels as shown.

76. Attach the under wing panels to the bar using M6 hex bolts and flat washers.

77. Attach the under wing panels to the mount brackets using M8 hex bolt and flat washers.



M6 - 7 Nm.



M8 - 22 Nm.



78. Trim the outer edge of the fender liner as shown so that it will clip in behind the bull bar.



79. Push the outer edge of the liner forward past the wing return edge so that it snaps in place

80. Carefully trim off the bottom of the guard liner level with the lower face of the wing under panel

81. Push up and tuck fender liner in behind the return flange on the wing under panel.



Warning: Cutting operations can result in flying debris, safety glasses should be worn.



82. Attach the centre stone shield to the bar as shown using M8 hex bolts (5), and flat washers.

Attach the stone shield to the vehicle using M6 hex bolts (2) and flat washers.

83. Centralise the panel and tighten the bolts.



M8 - 22 Nm.

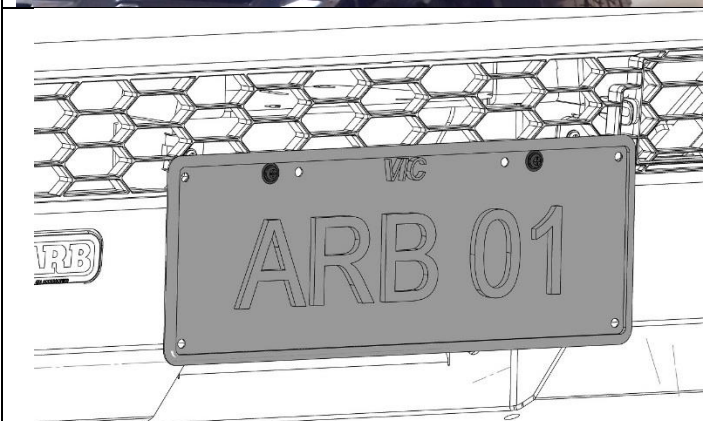

84. Fit the 2 larger plastic grommets into the license plate bracket.

85. Attach the license plate to the bracket using 2 self-tapping, Philips head screws.

Note: *This step applies to both the fixed and folding license plate brackets.*

NOTICE: ONCE SUMMIT BAR IS FITTED:

- ◆ Ensure all bolts are tensioned correctly.
- ◆ All wiring is clear of sharp edges or moving surfaces and secured properly.
- ◆ Piping is secured well away from sharp or moving components.
- ◆ Check operation of winch, if fitted.
- ◆ Check all wiring and connections to turn signal lamps, sensors, headlamp washers etc. are functioning correctly.
- ◆ Misalignment of parking sensor to hole in bull bar may cause malfunction, if fitted.
- ◆ Test operation of parking sensors after fitment, if fitted.

NOTE:

If parking sensors are fitted, do not add any accessories to the Bull Bar on or around the sensors, this may affect the function of the sensors.

Sensors may not function well under the following conditions:

- ◆ After the vehicle, has been sitting out in hot or cold weather.
- ◆ When the system is affected by electrical equipment or devices generating an ultrasonic wave.
- ◆ When operating in bad weather

FITTED PRODUCT

